



The manufacturer reserves the right to make changes to the product, release firmware updates, and update this manual at any time.

<https://www.okai.co/>

OKAI ES40



User Manual

Table of Contents

1. Introduction.....	02
1-1. Model Specifications.....	03
1-2. Icon Descriptions.....	05
1-3. Vehicle and Accessory List.....	06
2. Intended Usage.....	07
3. Safety Instructions.....	07
3-1. General Safety Instructions.....	07
3-2. RF exposure warning.....	09
3-3. Battery Safety.....	10
3-4. Charging Safety.....	10
4. Setting Up Your OKAI Scooter.....	11
4-1. Assembling.....	11
4-2. Front.....	13
4-3. Learn to drive.....	14
4-4. Preparations Before Riding.....	18
5. Maintenance, Cleaning, Storage and Transport.....	18
5-1. Maintenance.....	18
5-2. Cleaning.....	18
5-3. Storage and Transport.....	19
6. Disposal.....	19
7. Troubleshooting.....	20

Thank you for purchasing the OKAI electric scooter.

We wish you to ride OKAI electric scooter safely. As there could be risks in riding an electric scooter, please read this manual carefully before using and keep it for future references. For safety reasons, please make sure to pass on this manual to anyone you wish to lend your e-scooter to. Failure to follow the instructions in this manual could cause severe damage to the product. To facilitate readability, the OKAI electric scooter will be referred to as the product.

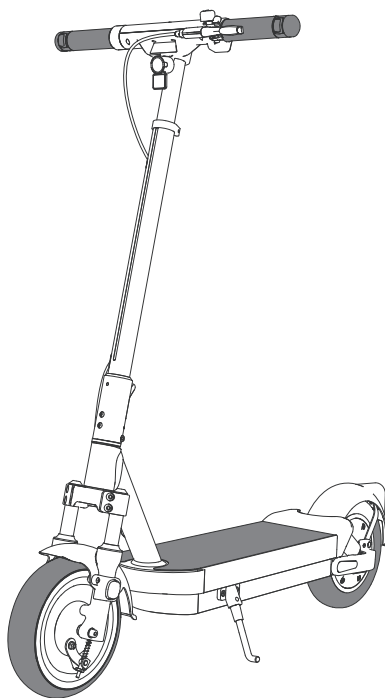

* The picture is for reference only. Please refer to the actual product for more details.

1-1. Model Specifications

Items	Specifications	ES40
Product Parameters	Unfolded: L*W*H	1175*575*1230(mm) (46.26*22.64*48.43inches)
	Folded: L*W*H	1175*575*535(mm) (46.26*22.64*21.06inches)
	Net Weight	23kg (50.7lbs)
	Maximum Speed	US: 38km/h (24mph) EU: 25km/h
	Typical Range*	70km (43.5miles)
	Maximum Slope	25%
	Terrain Adaptation	Flat surface/Mountains
	Operating Temperature	0~40°C
	Storage Temperature	-20~60°C
	IP Rating	IPX5
	Charging Time	3A<6H
Battery Parameters	Rated Voltage	47V
	Rated Capacity	15.6Ah
	Battery Management System	Negative Terminal Port
	Battery (Cell) Quantity	78 PCS
Motor Parameters	Motor Size	10 inches
	Maximum Torque	28N·m
	Rated Voltage	48V
	Rated Power	500W
	Maximum Power	1000W
	Motor Control Mode	Brushless Gearless Motor











Items	Specifications	ES40
Brakes	Brake Mode	Front: Drum Brake Rear: Electronic Brake
Tires	Tire Size	10 inches
	Tire Material	Vacuum Tire
Charger	Input Voltage	100-240V
	Output Voltage	54.6V
	Output Current	3A
	Model Reference	FY1695463000 made by Shenzhen Fuyuan Power Co.,Ltd.
Rider	Maximum Payload	120kg (264.55lbs)
	Recommended Age	14+ yrs.
	Required Height	120-200cm (3'11"-6'7")
Features	Brake Light	Brake highlighting
	Riding Mode	Button to turn on/off running lights
	Certifications	US: UL 2272, FCC, Prop65& 16 CFR1303 EU: EN17128, RoHS, WEEE
Package	Packaging	1 pc
	Gross Weight	28kg (61.7lbs)

*There will not be further notifications if the specification changes.

*Range: Riding on a full charge, with 75kg of payload, 25°C, and a consistent speed (60% of the maximum) on a flat terrain.

*The range is affected by many variables including: speed, temperature, terrain, number of starts and stops.

1-2. Icon Descriptions

DANGER	Indicates a danger condition that could lead to severe injuries or death.
WARNING	Indicates a warning condition that could lead to severe injuries or death.
CAUTION	Indicates a caution condition that could lead to severe injuries or death.
	Marks the additional information regarding the product and its usage.
	Indicates European Union's (EU) mandatory conformity marking for regulating the goods. Manufacturers use it to declare that their products comply with the EU's New Approach Directives.
	Please read this manual carefully before use.
	Display of positive and negative poles.
	Indicates that this is a Class II protective product.
	Please wear personal protective equipment (PPE).
	This product can only be used by one person at a time.
	This product can only be used on flat and dry roads.
	Please do not use this product after intake of alcohol, sedatives, or psychoactive medications.
	Minimum age requirement: 14 yrs.
	Please do not enter roads with these symbols.

1-3. Vehicle and Accessory List

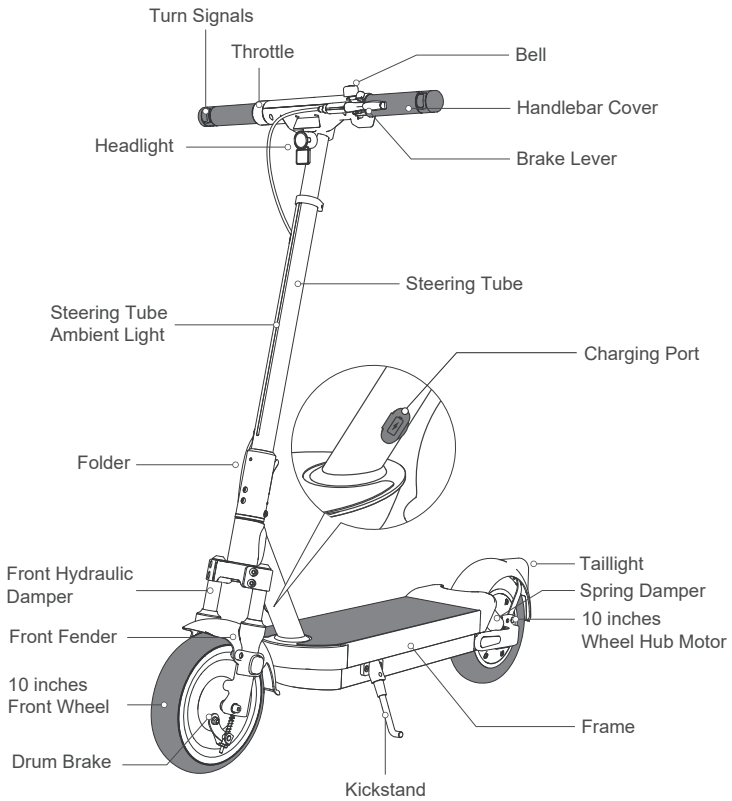

Dimensions: L:1175mm * W:575mm * H:1230mm

- The electric scooter is a recreational tool for sport rather than a means of transportation. However, once you drive an e-scooter into public areas (if the laws and regulations of your region or country allow it), it becomes a vehicle and therefore carries all the risks a vehicle might cause. Strictly following the instructions in this manual will reduce the risk of harming yourself and others to the greatest extent, and ensure compliance with national, provincial and municipal traffic laws and regulations.
- Please understand that when riding your e-scooter on public roads or other public areas (if the laws and regulations of your region or country allow it), there could be risks caused by violations of driving regulations or incorrect operations of other vehicles even if all the safety guidelines in this manual are strictly followed. The risks you might face are similar to that of walking or cycling on roads. Same as other vehicles, a longer braking distance is required when the e-scooter is at a fast speed. Sudden braking on smooth surfaces could cause the wheel to slip, lose balance, or fall. Therefore, it is very important to be cautious, maintain an appropriate speed, and keep a safe distance from pedestrians and vehicles while riding. When riding into an unfamiliar terrain, stay alert and drive at a low speed.
- Please respect the right-of-way of pedestrians when driving. Avoid startling pedestrians, especially children.
- When driving in China and other countries and regions where there are no national standards and regulations related to electric scooters, please make sure you follow the safety guidelines outlined in this manual. Zhejiang Okai Vehicle Co., Ltd. (OKAI) will not be responsible (directly or indirectly) for any financial and personal losses, accidents, legal disputes, or any other incidents that may cause conflict of interest as a result of using the scooter in violation of safety instructions in this manual.
- Do not let new riders ride your electric scooter on his/her own so as to avoid injuries. If you lend the e-scooter to a friend, his/her safety is your responsibility. Assist your friend until he/she is familiar with the basic operations of the scooter and make sure he/she wears protective gear.
- Please make a basic inspection of the electric scooter before each ride. Do not operate if you find obvious loose parts, significantly reduced battery life, excessive tire wear, malfunctioning steering, or other abnormal conditions.

3. Safety Instructions

This chapter lists the safety instructions that should be followed when using this product.

3-1. General Safety Instructions

Using this product might be dangerous! Take time to learn and practice how to use the product. Please understand that you can reduce the risks by following all the instructions and warnings in this manual, but you cannot eliminate all the risks. Therefore, even with adequate practice, instructions, and expertise, you still risk injuries from loss of control, collision, or fall.

1. Please keep the printed instructions for further reference and read the instructions carefully before use.
2. Maximum speed: US: 38km/h, EU: 25km/h.
3. This product should not be used by expectant mothers, people with disabilities, and people with heart, head, back or neck conditions (or who have had surgery on these areas).
4. Do not use this product after taking alcohol, sedatives, or psychotropic drugs as this may impair your judgment.
5. Please keep a distance of at least 1 meter from the pedestrians, vehicles, and obstacles.
6. Please use this product only when the environment permits and the safety of bystanders is guaranteed.
7. Pay attention to obstacles in front and in the distance, a clear view helps to ensure safety.
8. This product is for one rider. Do not ride with passengers or carry a child in your arms. Do not make sharp turns when driving at a high speed.

9. Avoid sudden acceleration or braking; Do not lean over and accelerate.
10. Do not move forward or backward excessively.
11. Do not use this product incorrectly. Do not use this product on roadways, motorways, areas close to motor vehicles, steps, swimming pools, slippery surfaces and other areas with water, uneven grounds, loose grounds, etc. where it may pose threats to your safety.
12. Do not use this product in areas with obstacles, slopes (especially steep slopes), icy surfaces, stairs, or escalators. Do not expose this product to rain.
13. Please do not use this product in areas where the depth of water exceeds 2cm to avoid water intrusion in the motor.
14. Do not jump up and down on this product. Do not use the product to do stunts or juggling.
15. In order to avoid distraction and monitor the environment, please do not use headphones, earplugs, make phone calls, take photos or videos, or conduct any other activities while riding.
16. Please keep both hands on the handlebar.
17. Do not use the product in the dark or in low visibility conditions.
18. When you encounter pedestrians or obstacles, please check whether you can pass safely.
19. Please use this product and its accessories at an appropriate temperature. Please note the temperature requirements for charging the battery.
20. Please wear personal protective equipment to protect your wrists, knees, head, and elbows from injury. In the operating area, local laws or regulations may have minimum requirements for helmets. In addition, it is recommended to wear safety reflectors.
21. The traffic regulations in France demands that riders wear reflective clothing and reflective helmet when riding.
22. Do not hitch a ride with another vehicle.
23. Park your vehicle with the kickstand on a flat and stable surface.
24. Adding weight to the handlebars will affect the stability of the vehicle.
25. **Warning!** In wet conditions, the braking distance will be extended.
26. **Warning!** When mechanical parts are subjected to great external pressure and friction, different materials and parts may perform differently. If a component exceeds the expected service life, it might break suddenly and cause injuries. Cracks, scratches and discoloration in the area affected by external pressure indicate that the component has exceeded its service life and should be replaced in time.
27. **Warning!** Keep the plastic cover away from children to avoid suffocation.
28. Please spend enough time to master the riding skills to avoid accidents caused by inexperience.
29. The seller can provide training courses if training is needed.
30. When approaching pedestrians or cyclists, you can dial/turn the bell to alert them.
31. Please step off and walk past the safe passage.
32. In any case, mind the safety of yourself and others.
33. Please do not use this product for other purposes such as carrying people and objects.
34. Do not touch the brake after riding so as to avoid burns due to heating.
35. Regularly inspect all kinds of bolts, especially the axles, folding system, steering system, and brake shaft.
36. Do not modify this product, including the steering tube, steering sleeve, steering lever, folding system, and rear brake.
37. Only use the accessories approved by the manufacturer.
38. The noise of riding shall not exceed 70dB.
39. Wear shoes when using the product.
40. Persons above 14 years old with physical, sensory, or mental disabilities/impairments or lack of experience and knowledge can use the product only under supervision and guidance regarding the safety operation and hazards. People under 14 years old should not use the product. Children are not allowed to clean or maintain this product without supervision.
41. Obstacles like curbs and steps are common in city traffic. It is recommended to avoid riding over obstacles. Before moving across these obstacles, it is necessary to predict and adapt to the path and speed of pedestrians. When these obstacles pose threats to your safety due to their shape, height or slippery surface, it is recommended that you step off and push the vehicle.
42. Contact your seller and ask him to recommend you a suitable training institution.
43. Avoid riding in areas with heavy traffic or crowds.
44. Plan your own path and speed while complying with the road regulations, sidewalk regulations, and regulations of the most vulnerable groups.

45. When approaching pedestrians or cyclists without being seen or heard by them, press the bell to alert them.
46. When pushing the vehicle, please walk in the safe passage.
47. Shut down the vehicle when charging.
48. Don't use the vehicle for other purposes.
49. Remove sharp edges resulting from use.
50. Self-tightening nuts and other self-tightening fasteners can become loose, Please check and tighten them up.
51. It is recommended to use mechanical locks to prevent the scooter from being stolen.
52. **Warning!** If the product is placed near the flame or at a high temperature, there will be risks of causing fire and electric shock.
53. Prolonged exposure to ultraviolet rays, rain, and other factors may damage the housing materials. Store the product indoors when not in use.
54. **WARNING!** Risk of Fire and Electric Shock - No User Serviceable Parts.
55. **AVERTISSEMENT!** Risque d'incendie et d'électrocution - Aucune pièce réparable par l'utilisateur.
56. Devices are not intended for use at elevations greater than 2000 m above sea level.

Failure to use common sense and pay attention to the above warnings while riding will increase the risk of serious injuries or even death. Please operate with care!

3-2. RF exposure warning

The device has been evaluated to meet general RF exposure requirement. The device can be used in portable exposure condition without restriction.

Any Changes or modifications not expressly approved by the party responsible for compliance could void the user's authority to operate the equipment.

⚠ NOTE: This equipment has been tested and found to comply with the limits for a Class B digital device, pursuant to part 15 of the FCC Rules. These limits are designed to provide reasonable protection against harmful interference in a residential installation. This equipment generates, uses and can radiate radio frequency energy and, if not installed and used in accordance with the instructions, may cause harmful interference to radio communications. However, there is no guarantee that interference will not occur in a particular installation. If this equipment does cause harmful interference to radio or television reception, which can be determined by turning the equipment off and on, the user is encouraged to try to correct the interference by one or more of the following measures:

1. Reorient or relocate the receiving antenna.
2. Increase the separation between the equipment and receiver.
3. Connect the equipment into an outlet on a circuit different from that to which the receiver is connected.
4. Consult the dealer or an experienced radio/TV technician for help.

3-3. Battery Safety

- Only use charging devices and batteries provided by the manufacturer.
- The battery charger should not be used by children under 18 years old, incapacitated people, people with mental disorders, etc., unless they are under the supervision or guidance of their guardians.
- Double check for damage to the plug and the cable. In case of damage, they must be replaced by the manufacturer, its service agent, or other qualified personnel to avoid causing danger.
- Disconnect the battery charger from the power source and let it cool before cleaning, storage and transport.
- Protect electrical parts from water. To avoid electric shock, do not immerse them in water or other liquids during cleaning or operating. Do not place the battery charger in water. When charging, the product must be placed in a well-ventilated area. Disconnect the charger from the power source as soon as the battery is fully charged.
- Regularly check the battery charger for damage. A damaged battery charger must be repaired before use. Do not use the battery charger if it was left outdoors for a long period of time or if it is damaged.
- Do not connect a damaged product to the battery charger. There is a risk of electric shock!
- Do not disassemble the battery charger. Repairment must be carried out by reliable after-sales service personnel. Improper assembling may cause a fire or electric shock.
- Do not use the charger near flammable and explosive materials. There is a risk of fire and explosion.
- Check the specifications before connecting the battery charger to the power source. Improper use may cause a fire! The battery charger is for indoor use only.
- Do not misuse the battery charger. The battery charger is only applicable to this product. Other uses may result in fire or electric shock.
- Make sure the battery charger and charging port are connected properly and not obstructed by other objects.
- Keep the charging port clean and dry, free from dust and moisture. Do not place any object on the battery charger and do not cover it, as this will cause the battery to overheat. Do not place the battery charger near a heat source.
- Be sure to place the power cord where no one will trip, step on, or damage it. Otherwise, there is a risk of property damage and personal injury.
- Do not disconnect the battery charger from the power source by pulling the power cord. Please pull out the plug manually.
- Do not use non-rechargeable batteries.

4. Setting Up Your OKAI Scooter

4-1. Assembling

This section provides information on how to use the product correctly. To ensure user safety and service life, it is important to follow these instructions.

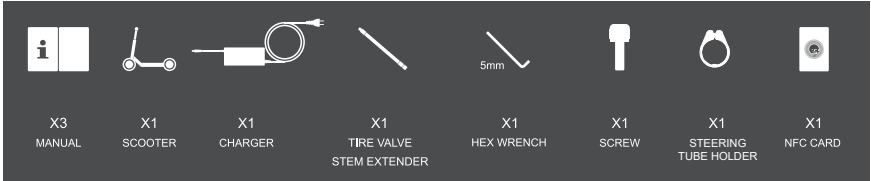

1. Take the vehicle out of the box, and remove all additional packaging around the vehicle. Lower the kickstand, then take out the tool kit and the charger box.

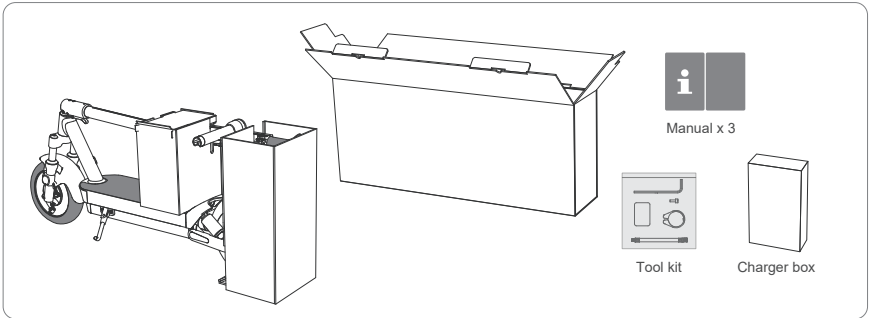

2. Unlock the steering tube, bring up the tube and handlebar.
a+b. Push down the lever to release the steering tube.
c. Bring up the front steering tube and the handlebar at the same time.
(The folding mechanism will lock automatically once in the upright position.)

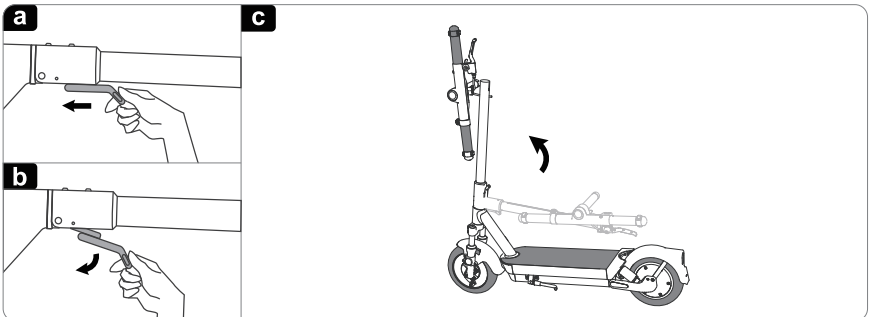

3. Next you'll want to install the handlebars.

- a. Install the steering tube holder to the upper end of the steering tube.
 - b. Connect the wiring harness between the handlebar and steering tube by their coordinating colors. Push the connected wires down into the tubes.
 - c. Push the handlebar down into the steering tube while matching the hole with the spring latch.
- After hearing the click sound, try to pull back the handlebar. If the handlebar cannot be pulled back, then the installation of this part is completed.
- d. The last step is to turn a 5mm hex wrench clockwise to tighten the bolt up.

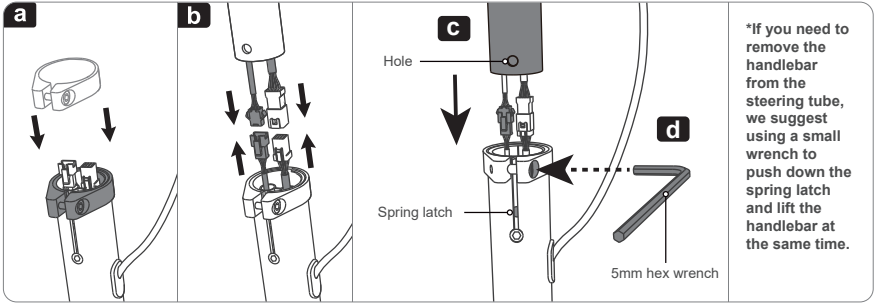

4. Lastly, you'll want to activate vehicle by following steps.

- a. Uncover the protective cover of the charging port located on the right side of the vehicle near the front of the deck.
- b. Connect one side of the charger into the charging port of the vehicle.
- c. Connect the other side of the charger into your power outlet/source.
- d. To activate the vehicle, press and hold the power switch located on the handlebar for 3 seconds and then release. The vehicle successfully activates when the dashboard illuminates and displays the current charging status.

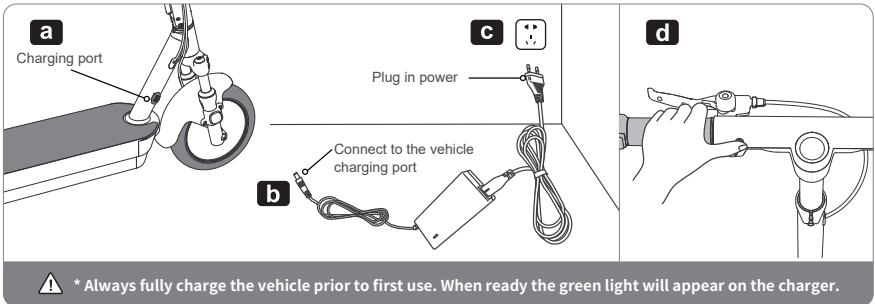

5. Once fully charged you'll be able to unplug the vehicle, close the charge port back up, hit the power button and enjoy your ride!

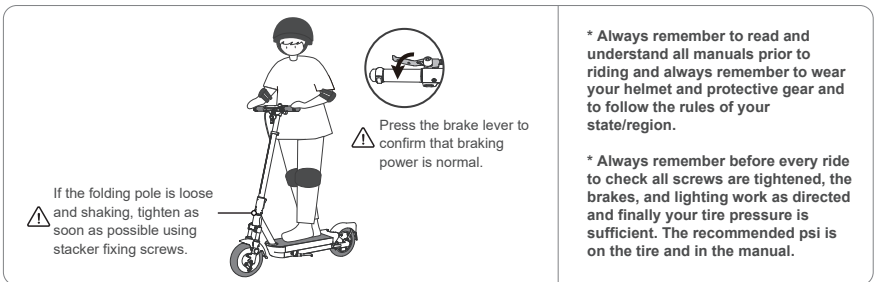

4-2. Front

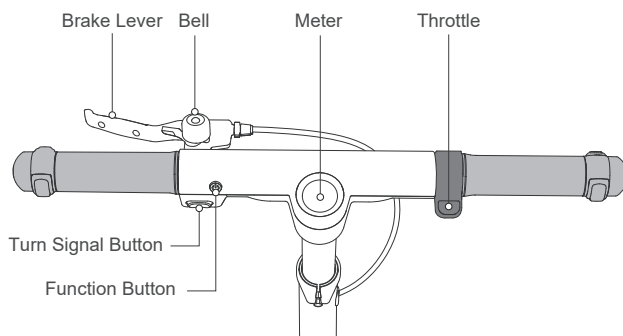

NFC card

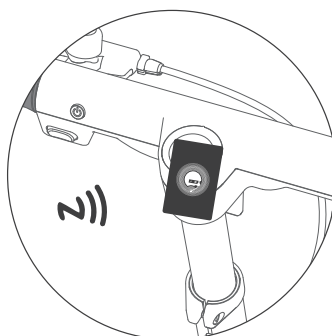

NFC card: when powered off, put the NFC card close to the screen to turn on and unlock the scooter; When powered on, place the NFC card close to the screen to shut down and lock the scooter.

Function button: Short press the function button to turn on the product, and hold it for about 3s to turn it off;

Press the function button to turn on/off the headlight when power-on; Press twice to switch to E (pedestrian mode) /L (economy mode) /H (sports mode) when power-on;

US: L 5km/h (3mph), E 20km/h (12mph), H 38km/h (24mph);
EU: L 5km/h, E 15km/h, H 25km/h.

APP turns on the cruise function, which maintains a constant speed. When the vehicle speed is greater than 10km/h, press and hold the function button for 2 seconds to enter cruise mode at constant speed; This function is not available in some regions due to regulatory requirements.

Brake handle: Squeeze the brake handle which will control both the disc brake and the electromagnetic brake;

Press the throttle to accelerate the scooter.

4-3. Learn to drive

1. Wear a helmet and protective gear.

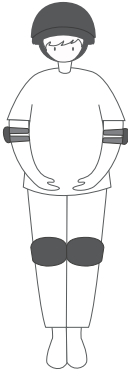

2. Please check the vehicle before each use.

⚠ If the folding pole is loose and shaking, tighten as soon as possible using stacker fixing screws.

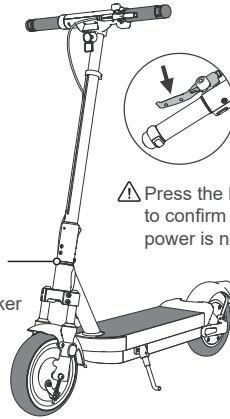

⚠ Press the brake lever to confirm that braking power is normal.

3. Put the other foot on the footstool to keep your feet stable. After maintaining your balance, press the throttle on the right to accelerate. For your safety, the electric motor will not start until the scooter reaches a speed of 4km/h(2.5 mph).

4. Release the acceleration handle to reduce speed, and squeeze the brake lever to brake.

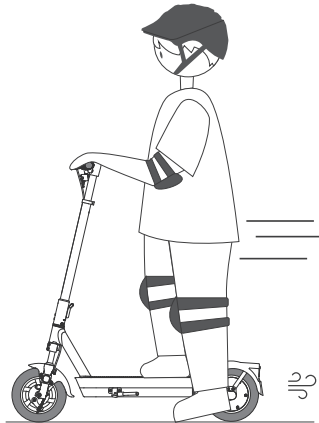

5. To change the center of gravity when turning, turn the handle slightly.

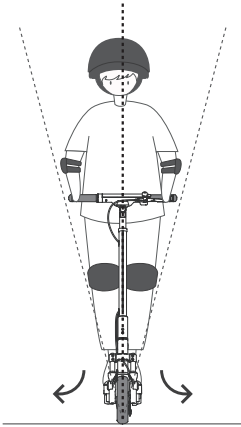

6. When you need to stop, release the acceleration handle to reduce speed, squeeze and brake the handlebar. Lay down the foot support and let the vehicle lean slightly in the foot support direction so that the foot support touches the ground, and the vehicle can be stabilized.

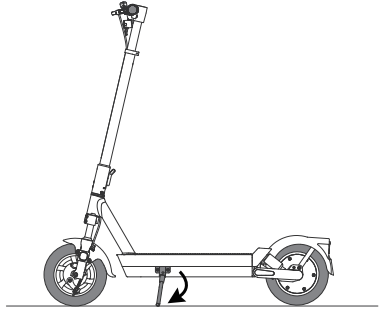

7. Warnings



Mind your speed when riding downhill.



Mind your head.



Mind vehicles.

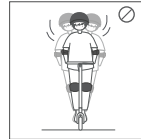

Do not shake the handlebar.



Do not check your phone.



Do not ride in the rain.

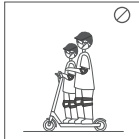

No passenger.



Keep both hands on the handlebar.

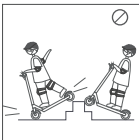

Do not ride over large gaps or steps.



Do not step on the fender.



Do not press the accelerator when walking.



Do not ride with one foot.



Do not put weight on the handlebar.

8. Folding operation

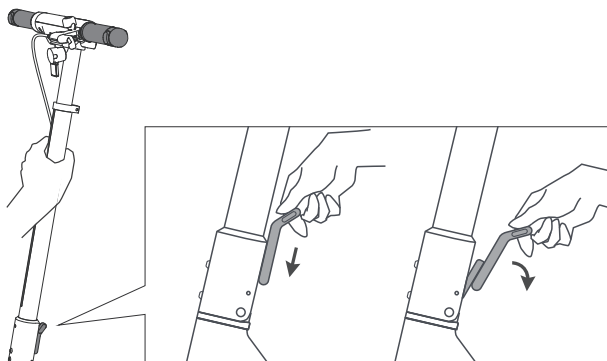

① Hold the front tube, press the folding handle down and then open it outwards;

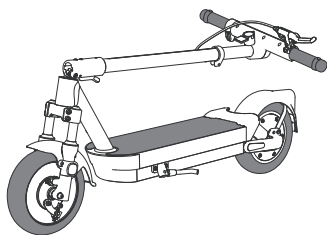

② Put down the front tube, the front tube is automatically locked;

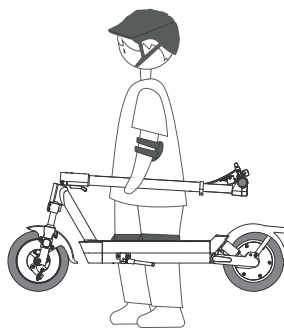

③ Hold the steering tube to lift the electric scooter.

9. Activate the app

Please scan the QR code to download the app (the system version and Bluetooth version are subject to the actual requirements of the app). You can find the cruise control function in the app, and discover more ways to use the scooter.



① Install APP, please register/login.

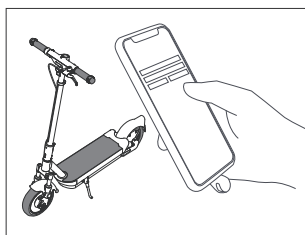

② Open the app, click "Search for Device". Follow the app prompt to pair with and connect to the scooter.

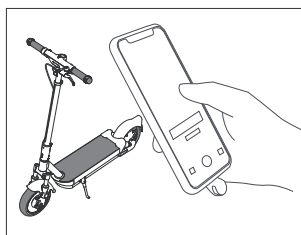

③ Watch the driving guide.

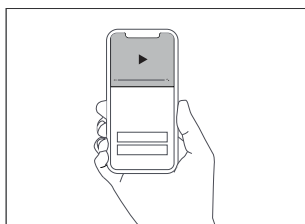

④ Start exploring a new riding experience.

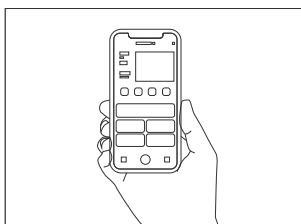

Now, you can use your scooter, check the status of the scooter and detect the scooter through the app. Please enjoy the ride.

4-4. Preparations Before Riding

Checklist:

- Wheels – Make sure the wheels are not damaged or excessively worn.
- Loose parts – Make sure all parts, such as nuts, bolts, and fasteners are well adjusted. There should be no abnormal sound from any part of the vehicle. Check it before each ride.
- Operating areas – Make sure the operating area is open, flat, and free of obstacles.
- Laws and regulations – Check and comply with local laws and regulations, especially when using this product on public roads.
- Safety equipment – Always wear personal protective equipment (for wrist, knee, head, and elbow protection). In some regions, there may be laws and regulations that require wearing helmets.

⚠ WARNING : Do not ride with only one hand. Do not do stunts while riding. Always ride with shoes on.

⚠ WARNING : Driving at a moderate speed can extend range. Driving at high speed constantly and frequent acceleration, deceleration, start, stop, and idling will reduce range.

⚠ WARNING : Do not touch the brake parts with your hands after continuous braking.

5. Maintenance, Cleaning, Storage and Transport

5-1. Maintenance

The maintenance of this product and its accessories shall be carried out in accordance with the Standard Operating Procedure (SOP) provided by our company. If the unit needs maintenance or there are other problems, please contact the seller. Replace the front or rear wheel if the bearing is damaged.

5-2. Cleaning

- Please turn off the power and unplug the battery charger from the product before cleaning.
- Do not use solvents or abrasive detergent. Do not use hard brushes, metal, or sharp objects to clean as they may severely damage both the exterior and interior of the vehicle.
- Clean the battery charger and the product with a wet cloth, then wipe off with a dry cloth.

⚠ WARNING : Do not immerse the product or battery charger in water or other liquids. Do not place the product or battery charger under running water. There is a risk of electric shock!

⚠ WARNING : Do not clean this product with a jetting machine.

5-3. Storage and Transport

- Store the product in a dry and clean place away from children, preferably in its original packaging.
- Shut down the product before transport.
- Only transport the product in its original packaging. Do not throw away the packaging as it could be used for future transportation. Protect the product during transport (e.g., use Bungee straps) and prevent it from falling, overturning, external impact, and shake, especially when it is transported by vehicles.

⚠ WARNING : This product contains a built-in lithium battery. Lithium batteries are considered as dangerous goods that can only be transported if local laws and regulations allow.



: If you plan to travel with the product by air or other means of transportation, please confirm with your transportation company whether the product is allowed to transport.

6. Disposal



This mark indicates that this product should not be disposed of with other household waste throughout the European Union regions. To prevent possible harms to the environment and health of human beings from unbounded waste disposal, it is our responsibility to recycle it in order to promote the sustainable use of resources. To dispose of used products, please contact recycling organizations or the retailer of the product. They will recycle this product in an environmentally friendly manner.



Dispose of the battery according to environment protection requirements. Do not throw away the battery together with the household waste. Contact the recycling organization in your community or the retailer of this product.



Packaging materials can be transferred back to the raw material cycle. Dispose of packaging materials in accordance with legal requirements. Information can be obtained from your community's recycling organization.

7. Explanation of error codes

Error number	Error name	The reason	Troubleshooting method
01E	Overcurrent protection	The instantaneous output current of the controller exceeds the current limit range (>22A)	The controller output current is less than 22A and then recovers
02E	Undervoltage protection	When the battery voltage is lower than 40±1V	1. The fault is resolved automatically after charging 2. Replace the battery
03E	Motor phase line failure	Short circuit of motor phase line when unlocking	1. Replace the motor 2. Replace the controller
04E	Locked-rotor protection	The motor is blocked or short-circuited, or the drive is faulty	1. Release the locked-rotor state 2. Replace the motor
05E	The upper MOS tube is damaged	The drive upper bridge MOS tube is damaged or broken down	Replace the controller
06E	Damaged lower MOS tube	The driving lower bridge MOS tube is damaged or broken down	Replace the controller
07E	Motor Hall failure	The hall wiring sequence is wrong or the connection is bad	1. The plug-in connection is bad, reconnect it 2. Replace the motor
08E	Motor overheated	Motor temperature exceeds the normal operating temperature	1. Stop riding and cool down, and wait for the fault to be resolved by itself 2. Replace the motor
09E	Lever failure	Handlebar malfunction or poor connection	1. Check the connection of the switch handle and eliminate the poor contact 2. Replace the handle 3. Release the handle
10E	Left brake failure	Left brake lever Hall failure or poor connection	1. Check the brake lever wiring to eliminate poor contact 2. Replace the left brake lever
11E	Electronic control receiving timeout failed	The instrument communication connector is faulty or the device is faulty	1. Check the wiring of the instrument and the central control harness plug-in of the instrument, and eliminate the poor contact 2. Replace the meter

Error number	Error name	The reason	Troubleshooting method
12E	Controller dropped	The instrument communication connector is faulty or the device is faulty	<ol style="list-style-type: none"> 1. Check the wiring of the instrument and the central control harness plug-in of the instrument, and eliminate the poor contact 2. Replace the controller
13E	Battery communication failure	Poor contact of the battery communication line or defective device	<ol style="list-style-type: none"> 1. Check the controller battery wiring and eliminate the bad wiring 2. Replace the controller 3. Replacement battery
15E	Controller firmware is missing	Controller program upgrade failed	<ol style="list-style-type: none"> 1. Re-upgrade the controller program 2. Replace the controller
16E	Battery protection board is missing	Battery program upgrade failed	<ol style="list-style-type: none"> 1. Re-upgrade the battery program 2. Replacement battery
17E	Instrument firmware is missing	Instrument program upgrade failed	<ol style="list-style-type: none"> 1. Re-upgrade the instrument program 2. Replace the controller
18E	Handlebar does not return	The handle turns back into position when turning on or the handle is damaged	<ol style="list-style-type: none"> 1. Put the transfer back into place 2. Replace the handle 3. Release the handle
19E	Left brake lever is not reset	The left brake does not return or the left brake is damaged when starting up	<ol style="list-style-type: none"> 1. Return the left brake lever 2. Replace the left brake
20E	Battery overheating protection	The battery temperature is abnormally high	<ol style="list-style-type: none"> 1. Let the vehicle stand by for a minimum of 30 minutes. Allow the battery temperature to decrease before restarting. 2. Replace the battery.
21E	Controller overheating protection	The controller temperature is abnormally high	<ol style="list-style-type: none"> 1. Let the vehicle stand by for a minimum of 30 minutes. Allow the controller temperature to decrease before restarting. 2. Replace the controller.
22E	Motor phase line disconnected	Motor failure or poor connection	<ol style="list-style-type: none"> 1. Check the wire connection between the motor and the controller. 2. Replace the motor.