



The manufacturer reserves the right to make changes to the product,
release firmware updates, and update this manual at any time.
<https://cn.okai.co>

OKAI ES800



User Manual

Table of Contents

1. Introduction.....	02
1-1. Model Specifications.....	03
1-2. Icon Descriptions.....	05
1-3. Vehicle and Accessory Lis.....	06
2. Intended Usage.....	07
3. Safety Instructions.....	07
3-1. General Safety Instructions.....	07
3-2. Battery Safety.....	09
3-3. Charging Safety.....	09
4. Setting Up Your OKAI Scooter.....	10
4-1. Assembling.....	10
4-2. Front.....	13
4-3. Preparations Before Riding.....	18
5. Maintenance, Cleaning, Storage and Transport.....	18
5-1. Maintenance.....	18
5-2. Cleaning.....	18
5-3. Storage and Transport.....	19
6. Disposal.....	19
7. Troubleshooting.....	20

Thank you for purchasing the OKAI electric scooter.

We wish you to ride OKAI electric scooter safely. As there could be risks in riding an electric scooter, please read this manual carefully before using and keep it for future references. For safety reasons, please make sure to pass on this manual to anyone you wish to lend your e-scooter to. Failure to follow the instructions in this manual could cause severe damage to the product. To facilitate readability, the OKAI electric scooter will be referred to as the product.

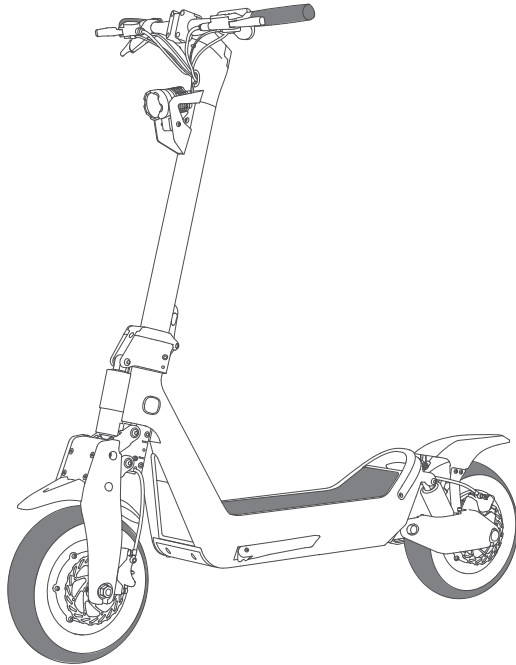

* The picture is for reference only. Please refer to the actual product for more details.

1-1. Model Specifications

Items	Specifications	ES800
Product Parameters	Unfolded: L*W*H	1322*608*1263(mm)
	Folded: L*W*H	1322*608*680(mm)
	Net Weight	43kg
	Maximum Speed	37mph
	Typical Range*	31miles
	Maximum Slope	35%
	Terrain Adaptation	Flat surface/Mountains
	Operating Temperature	-10~40 C
	Storage Temperature	-20~50 C
	IP Rating	(Vehicle) IP55
	Charging Time	4A<5h
Battery Parameters	Rated Voltage	51V
	Rated Capacity	19.2Ah
	Battery Management System	Negative Terminal Port
	Battery (Cell) Quantity	84 PCS
	Swappable Battery	Yes
	Charging Cabinet Version	/
Motor Parameters	Motor Size	12 inches
	Maximum Torque	60N.m
	Rated Voltage	51V
	Rated Power	1500W
	Maximum Power	3000W
	Motor Control Mode	Brushless Gearless Motor











Items	Specifications	ES800
Brakes	Braking Distance	< 10m
	Brake Mode	Front & Rear: Disc Brake + Electronic Brake
Tires	Tire Size	12 inches
	Tire Material	Tubeless Tire
Charger	Input Voltage	100-240V
	Output Voltage	58.8V
	Output Current	4A
Rider	Maximum Payload	150kg
	Recommended Age	18+ yrs.
	Required Height	140-200cm
Features	Brake Light	Blinking of dim light/off
	Riding Mode	Dim Taillight
	Certifications	FCC, UN38.3 Certification
Package	Packaging	1 pc
	Gross Weight	48kg

*There will not be further notifications if the specification changes.

*Range: Riding on a full charge, with 75kg of payload, 25 C, and a consistent speed (60% of the maximum) on a flat terrain.

*The range is affected by many variables including: speed, temperature, terrain, number of starts and stops.

1-2. Icon Descriptions

DANGER	Indicates a danger condition that could lead to severe injuries or death.
WARNING	Indicates a warning condition that could lead to severe injuries or death.
CAUTION	Indicates a caution condition that could lead to severe injuries or death.
	Marks the additional information regarding the product and its usage.
	Indicates European Union's (EU) mandatory conformity marking for regulating the goods. Manufacturers use it to declare that their products comply with the EU's New Approach Directives.
	Please read this manual carefully before use.
	Display of positive and negative poles.
	Indicates that this is a Class II protective product.
	Please wear personal protective equipment (PPE).
	This product can only be used by one person at a time.
	This product can only be used on flat and dry roads.
	Please do not use this product after intake of alcohol, sedatives, or psychoactive medications.
	Minimum age requirement: 18 yrs.
	Please do not enter roads with these symbols.

1-3. Vehicle and Accessory List

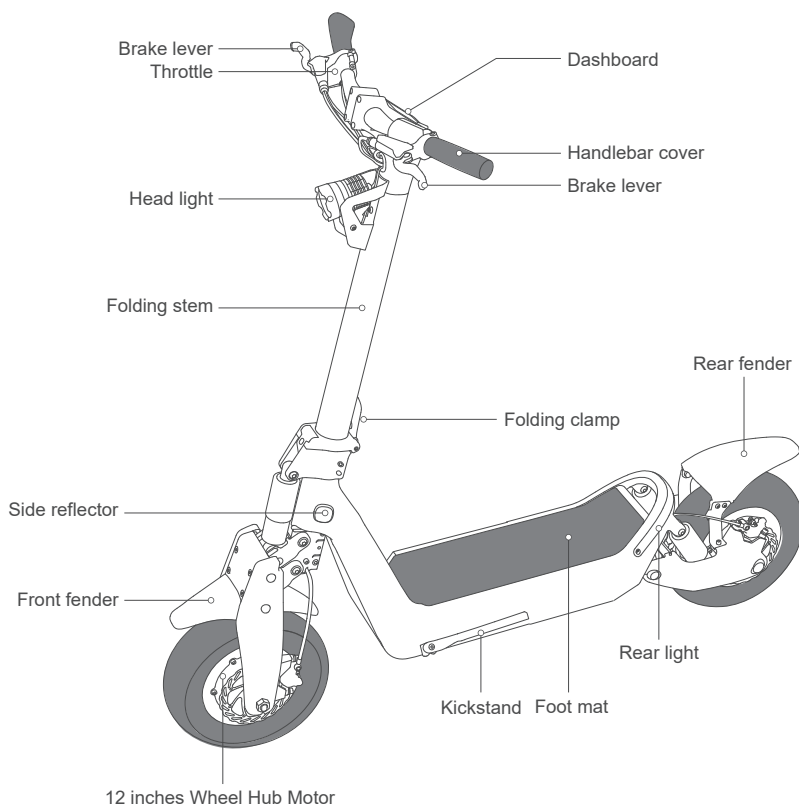

Dimensions: L:1322mm * W:608mm * H:1263mm

The electric scooter is a recreational tool for sport rather than a means of transportation. However, once you drive an e-scooter into public areas (if the laws and regulations of your region or country allow it), it becomes a vehicle and therefore carries all the risks a vehicle might cause. Strictly following the instructions in this manual will reduce the risk of harming yourself and others to the greatest extent, and ensure compliance with national, provincial and municipal traffic laws and regulations.

Please understand that when riding your e-scooter on public roads or other public areas (if the laws and regulations of your region or country allow it), there could be risks caused by violations of driving regulations or incorrect operations of other vehicles even if all the safety guidelines in this manual are strictly followed. The risks you might face are similar to that of walking or cycling on roads. Same as other vehicles, a longer braking distance is required when the e-scooter is at a fast speed. Sudden braking on smooth surfaces could cause the wheel to slip, lose balance, or fall. Therefore, it is very important to be cautious, maintain an appropriate speed, and keep a safe distance from pedestrians and vehicles while riding. When riding into an unfamiliar terrain, stay alert and drive at a low speed.

Please respect the right-of-way of pedestrians when driving. Avoid startling pedestrians, especially children.

When driving in China and other countries and regions where there are no national standards and regulations related to electric scooters, please make sure you follow the safety guidelines outlined in this manual. Zhejiang Okai Vehicle Co., Ltd. (OKAI) will not be responsible (directly or indirectly) for any financial and personal losses, accidents, legal disputes, or any other incidents that may cause conflict of interest as a result of using the scooter in violation of safety instructions in this manual.

Do not let new riders ride your electric scooter on his/her own so as to avoid injuries. If you lend the e-scooter to a friend, his/her safety is your responsibility. Assist your friend until he/she is familiar with the basic operations of the scooter and make sure he/she wears protective gear.

Please make a basic inspection of the electric scooter before each riding. If you find obvious loose parts, battery life significantly reduced, excessive tire wear, steering noises or malfunction, and other abnormal conditions.

3. Safety Instructions

This chapter lists the safety instructions that should be followed when using this product.

3-1. General Safety Instructions

Using this product might be dangerous! Take time to learn and practice how to use the product. Please understand that you can reduce the risks by following all the instructions and warnings in this manual, but you cannot eliminate all the risks. Therefore, even with adequate practice, instructions, and expertise, you still risk injuries from loss of control, collision, or fall.

1. Please keep the printed instructions for further reference and read the instructions carefully before use.
2. Maximum speed: 60km/h.
3. This product should not be used by expectant mothers, people with disabilities, and people with heart, head, back or neck conditions (or who have had surgery on these areas).
4. Do not use this product after taking alcohol, sedatives, or psychotropic drugs as this may impair your judgment.
5. Please keep a distance of at least 1 meter from the pedestrians, vehicles, and obstacles.
6. Please use this product only when the environment permits and the safety of bystanders is guaranteed.
7. Pay attention to obstacles in front and in the distance, a clear view helps to ensure safety.
8. This product is for one rider. Do not ride with passengers or carry a child in your arms. Do not make sharp turns when driving at a high speed.

9. Avoid sudden acceleration or braking; Do not lean over and accelerate.
10. Do not move forward or backward excessively.
11. Do not use this product incorrectly. Do not use this product on roadways, motorways, areas close to motor vehicles, steps, swimming pools, slippery surfaces and other areas with water, uneven grounds, loose grounds, etc. where it may pose threats to your safety.
12. Do not use this product in areas with obstacles, slopes (especially steep slopes), icy surfaces, stairs, or escalators. Do not expose this product to rain.
13. Please do not use this product in areas where the depth of water exceeds 2cm to avoid water intrusion in the motor.
14. Do not jump up and down on this product. Do not use the product to do stunts or juggling.
15. In order to avoid distraction and monitor the environment, please do not use headphones, earplugs, make phone calls, take photos or videos, or conduct any other activities while riding.
16. Please keep both hands on the handlebar.
17. Do not use the product in the dark or in low visibility conditions.
18. When you encounter pedestrians or obstacles, please check whether you can pass safely.
19. Please use this product and its accessories at an appropriate temperature. Please note the temperature requirements for charging the battery.
20. Please wear personal protective equipment to protect your wrists, knees, head, and elbows from injury. In the operating area, local laws or regulations may have minimum requirements for helmets. In addition, it is recommended to wear safety reflectors.
21. The traffic regulations in French demands that riders wear reflective clothing and reflective helmet when riding.
22. Do not hitch a ride with another vehicle.
23. Park your vehicle with the kickstand on a flat and stable surface.
24. Adding weight to the handlebars will affect the stability of the vehicle.
25. **Warning!** In wet conditions, the braking distance will be extended.
26. **Warning!** When mechanical parts are subjected to great external pressure and friction, different materials and parts may perform differently. If a component exceeds the expected service life, it might break suddenly and cause injuries. Cracks, scratches and discoloration in the area affected by external pressure indicate that the component has exceeded its service life and should be replaced in time.
27. **Warning!** Keep the plastic cover away from children to avoid suffocation.
28. Please spend enough time to master the riding skills to avoid accidents caused by inexperience.
29. The seller can provide training courses if training is needed.
30. When approaching pedestrians or cyclists, you can dial/turn the bell to alert them.
31. Please step off and walk past the safe passage.
32. In any case, mind the safety of yourself and others.
33. Please do not use this product for other purposes such as carrying people and objects.
34. Do not touch the brake after riding so as to avoid burns due to heating.
35. Regularly inspect all kinds of bolts, especially the axles, folding system, steering system, and brake shaft.
36. Do not modify this product, including the steering tube, steering sleeve, steering lever, folding system, and rear brake.
37. Only use the accessories approved by the manufacturer.
38. The noise of riding shall not exceed 70dB.
39. Wear shoes when using the product.
40. Persons above 18 years old with defective physical, sensory or mental abilities or lack of experience and knowledge can use the product only under supervision and guidance regarding the safety operation and hazards. People under 18 years old should not use the product. Children are not allowed to clean or maintain this product without supervision.
41. Obstacles like curbs and steps are common in city traffic. It is recommended to avoid riding over obstacles. Before moving across these obstacles, it is necessary to predict and adapt to the path and speed of pedestrians. When these obstacles pose threats to your safety due to their shape, height or slippery surface, it is recommended that you step off and push the vehicle.
42. Contact your seller and ask him to recommend you a suitable training institution.
43. Avoid riding in areas with heavy traffic or crowds.
44. Plan your own path and speed while complying with the road regulations, sidewalk regulations, and regulations of the most vulnerable groups.

45. When approaching pedestrians or cyclists without being seen or heard by them, press the bell to alert them.
46. When pushing the vehicle, please walk in the safe passage.
47. Shut down the vehicle when charging.
48. Don't use the vehicle for other purposes.
49. Remove sharp edges resulting from use.
50. Self-tightening nuts and other self-tightening fasteners can become loose, Please check and tighten them up.
51. It is recommended to use mechanical locks to prevent the scooter from being stolen.
52. **Warning!** If the product is placed near the flame or at a high temperature, there will be risks of causing fire and electric shock.
53. Prolonged exposure to ultraviolet rays, rain, and other factors may damage the housing materials. Store the product indoors when not in use.
54. **WARNING!** Risk of Fire and Electric Shock – No User Serviceable Parts.
55. **AVERTISSEMENT!** Risque d'incendie et d'électrocution – Aucune pièce réparable par l'utilisateur.

Failure to use common sense and pay attention to the above warnings while riding will increase the risk of serious injuries or even death. Please operate with care!

3-2. Battery Safety

- The battery shall not be exposed to overheated conditions such as in sunlight, fire, etc. There is a risk of explosion!
- Fully charge the battery before a storage of over 30 days.
- Fully charge the battery every 90 days to avoid over-discharge, which will cause permanent damage to the battery.
- Stop using the product if the battery emits a strong odor or becomes hot. Do not open the housing of the product or make any attempt to disassemble the battery.
- Dispose of and recycle the battery in a correct and safe manner.

3-3. Charging Safety

- Only use charging devices and batteries provided by the manufacturer.
- The battery charger should not be used by children under 18 years old, incapacitated people, people with mental disorders, etc., unless they are under the supervision or guidance of their guardians.
- Double check for damage to the plug and the cable. In case of damage, they must be replaced by the manufacturer, its service agent, or other qualified personnel to avoid causing danger.
- Disconnect the battery charger from the power source and let it cool before cleaning, storage and transport.
- Protect electrical parts from water. To avoid electric shock, do not immerse them in water or other liquids during cleaning or operating. Do not place the battery charger in water. When charging, the product must be placed in a well-ventilated area. Disconnect the charger from the power source as soon as the battery is fully charged.
- Regularly check the battery charger for damage. A damaged battery charger must be repaired before use. Do not use the battery charger if it was left outdoors for a long period of time or if it is damaged.
- Do not connect a damaged product to the battery charger. There is a risk of electric shock!
- Do not disassemble the battery charger. Repairment must be carried out by reliable after-sales service personnel. Improper assembling may cause a fire or electric shock.
- Do not use the charger near flammable and explosive materials. There is a risk of fire and explosion.

- Check the specifications before connecting the battery charger to the power source. Improper use may cause a fire! The battery charger is for indoor use only.
- Do not misuse the battery charger. The battery charger is only applicable to this product. Other uses may result in fire or electric shock.
- Make sure the battery charger and charging port are connected properly and not obstructed by other objects.
- Keep the charging port clean and dry, free from dust and moisture. Do not place any object on the battery charger and do not cover it, as this will cause the battery to overheat. Do not place the battery charger near a heat source.
- Be sure to place the power cord where no one will trip, step on, or damage it. Otherwise, there is a risk of property damage and personal injury.
- Do not disconnect the battery charger from the power source by pulling the power cord. Please pull out the plug manually.
- Do not charge the non-rechargeable batteries.

4. Setting Up Your OKAI Scooter

4-1. Assembling

This section provides information on how to use the product correctly. For the safety of users and a prolonged service life of the product, it is crucial to follow these instructions.

1. Cut off the packing straps of the box, take out the instruction manual, tool kit, charger, handlebar clamp, and two pieces of foam board.

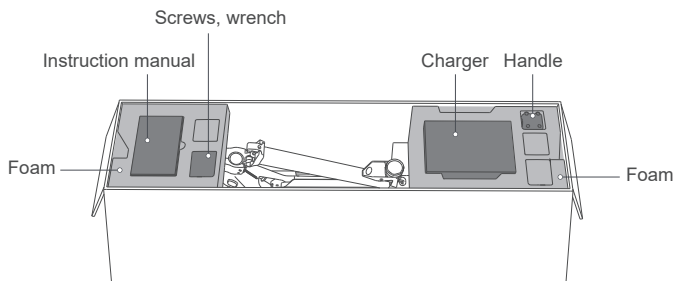

2. Remove the box and the plastic packaging.

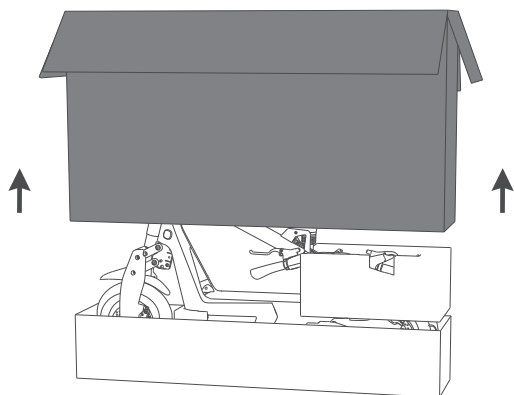

3. ① Hold up the handlebar and the folding stem at the same time; ② Snap the folding stem into the lower part; ③ Snap the folding device upwards to lock the folding device.

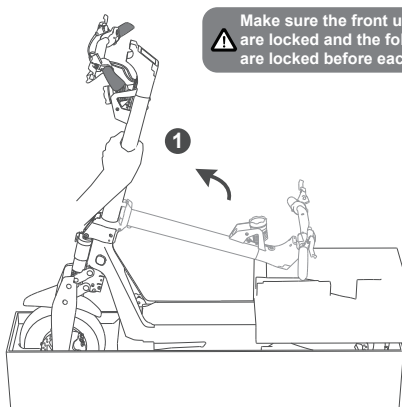
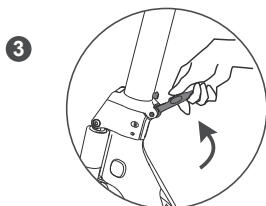
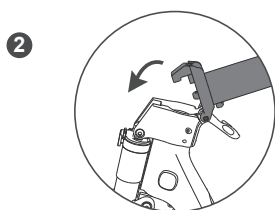

⚠ Make sure the front uprights are locked and the folding handles are locked before each ride.

4. Take out the handlebar clamp and attach it to the handlebar with a 4mm Allen wrench.

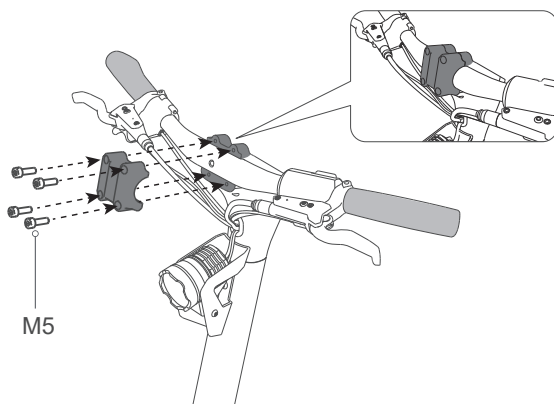

5. Remove the remaining foam pieces and plastic packaging, take out the vehicle, and unfold the kickstand.

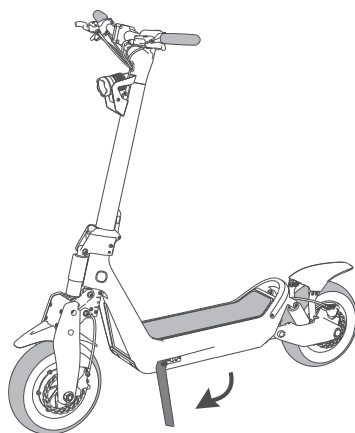

⚠ Note: For first use, please connect the charger to activate vehicle.

4-2. Front

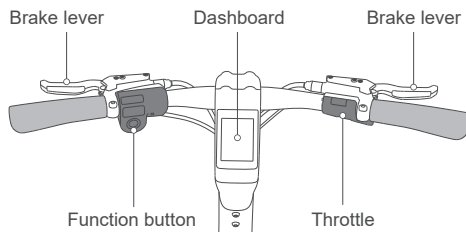

Function Description

Mode adjustment

Push up: upshift
Push down: downshift (non-cyclic)

Mode description:

- E** is the pedestrian mode, the maximum speed is 5km/h, applicable for pushing on sidewalks;
- D** is the economy mode, the maximum speed is 25mph
- B** is the sport mode, the maximum speed is 37mph.

Turn left

Click to turn on the corresponding turn signal, click again to turn off.

Turn right**Horn horn/power**

Short press to turn on,
long press about 3 seconds to turn off.
Vehicle driving status:
honk the horn

Front and rear light switch

Press the middle position to trigger the left and right steering switches at the same time, turn on the headlights and taillights;
Click again simultaneously to turn off the headlights and taillights.

Reset switch

When the instrument crashes or the system crashes, press it to restart the system forcibly.

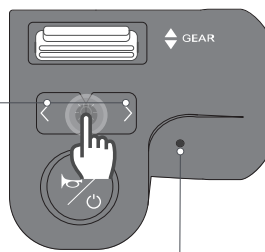
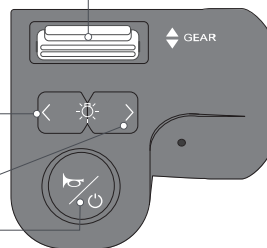

NFC key

In the off state, the NFC key card is close to the screen to turn on and unlock;

In the power on state, the NFC key card is close to the screen, shut down and lock the scooter.

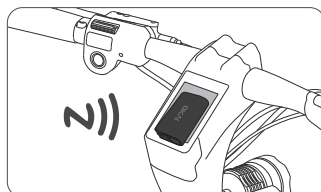

1. Wear a helmet and other protective equipment.

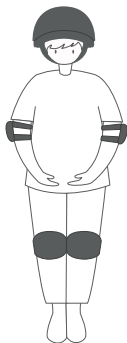

2. Inspect the vehicle before use.

△ If the folding stem is loose and wobble, tighten the screws of the folding device in time.

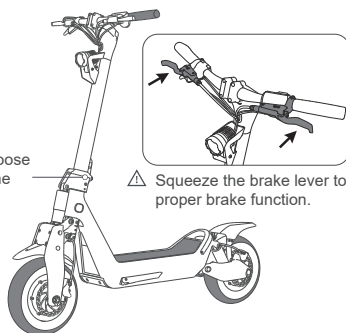

△ Squeeze the brake lever to confirm proper brake function.

3. Kick the ground to give the vehicle an initial speed, press the rotary handle to accelerate.

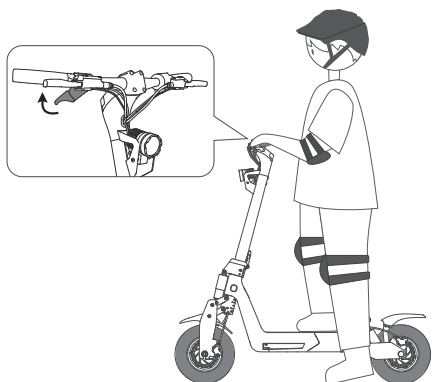

4. Release the rotary handle to slow down and squeeze the brake lever to stop.

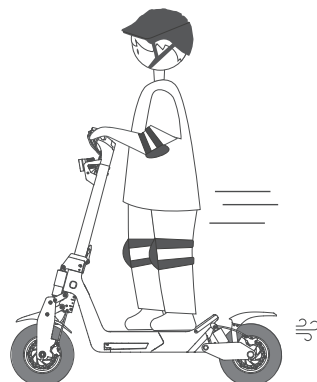

5. To turn, shift your body and turn the handlebar slightly.

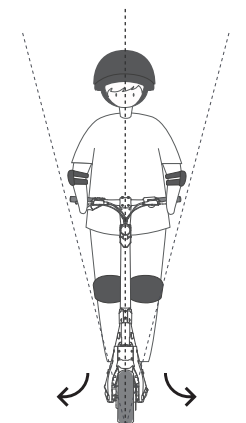

6. To stop, release the rotary handle to slow down and squeeze the brake lever. Unfold the kickstand and let the vehicle lean slightly so that the kickstand meets the ground, and then the vehicle can be placed stably.

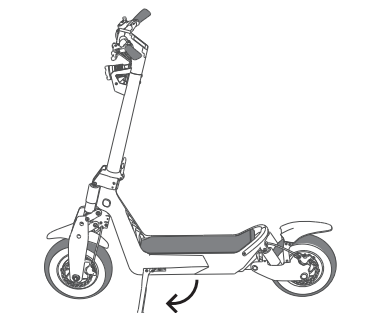

7. Warnings



Mind your speed when riding downhill.



Mind your head.



Mind vehicles.

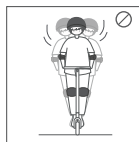

Do not shake the handlebar.



Do not check your phone.



Do not ride in the rain.



No passenger.



Keep both hands on the handlebar.

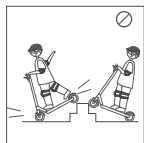

Do not ride over large gaps or steps.



Do not step on the fender.



Do not press the accelerator when walking.



Do not ride with one foot.

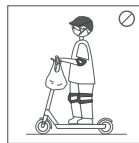

Do not put weight on the handlebar.

8. Folding and Carrying

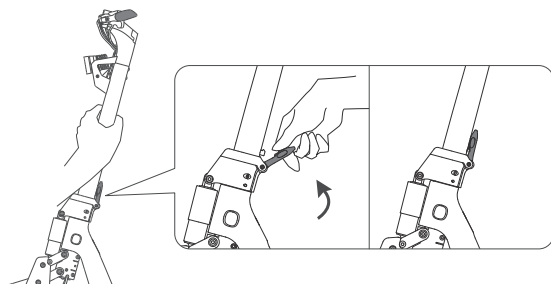

- ① Hold the folding stem, gently flip down the folding pedal, and bend outwards;

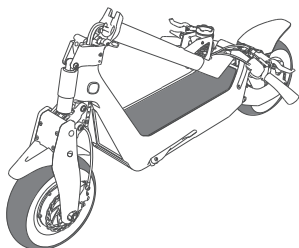

- ② Put down the folding stem and it will be locked automatically;

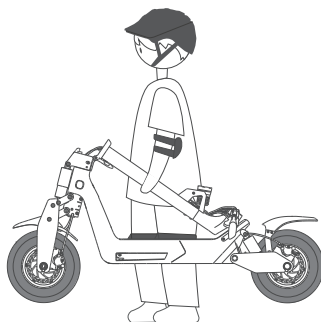

- ③ Lift the vehicle by the stem to carry around.

9. Activating the OKAI App

Scan the QR code to install the App on your mobile device (see the system and Bluetooth version requirements in the App). The cruise control function and other recreational functions of the scooter can be found in the App. Please charge and activate the vehicle before connecting it to the App.



① Install APP, please register/login

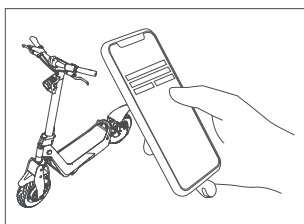

② Open the app, click "Search device", follow the prompts to connect to your scooter.

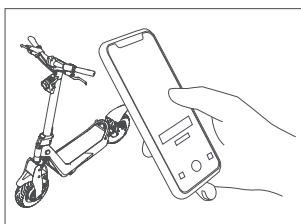

③ Watch the riding tutorial.

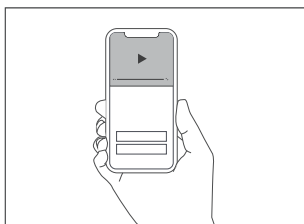

④ Explore novel riding experiences.

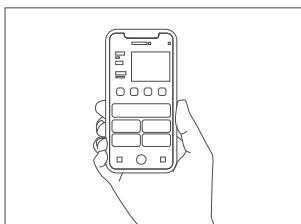

Now, you can use your vehicle, check for status, and inspect the vehicle through the App. We wish you a pleasant ride.

4-3. Preparations Before Riding

Checklist:

- Wheels – Make sure the wheels are not damaged or excessively worn.
- Loose parts – Make sure all parts, such as nuts, bolts, and fasteners are well adjusted. There should be no abnormal sound from any part of the vehicle. Check it before each ride.
- Operating areas – Make sure the operating area is open, flat, and free of obstacles.
- Laws and regulations – Check and comply with local laws and regulations, especially when using this product on public roads.
- Safety equipment – Always wear personal protective equipment (for wrist, knee, head, and elbow protection). In some regions, there may be laws and regulations that require wearing helmets.

⚠ WARNING : Do not ride with only one hand. Do not do stunts while riding. Always ride with shoes on.

⚠ WARNING : Driving at a moderate speed can extend range. Driving at high speed constantly and frequent acceleration, deceleration, start, stop, and idling will reduce range.

⚠ WARNING : Do not touch the brake parts with your hands after continuous braking.

5. Maintenance, Cleaning, Storage and Transport

5-1. Maintenance

The maintenance of this product and its accessories shall be carried out in accordance with the Standard Operating Procedure (SOP) provided by our company. If the SOP needs maintenance or there are other problems, please contact the seller. Replace the front or rear wheel if the bearing is damaged.

5-2. Cleaning

- Please turn off the power and unplug the battery charger from the product before cleaning.
- Do not use solvents or abrasive detergent. Do not use hard brushes, metal, or sharp objects to clean as they may severely damage both the exterior and interior of the vehicle.
- Clean the battery charger and the product with a wet cloth, then wipe off with a dry cloth.

⚠ WARNING : Do not immerse the product or battery charger in water or other liquids. Do not place the product or battery charger under running water. There is a risk of electric shock!

⚠ WARNING : Do not clean this product with a jetting machine.

5-3. Storage and Transport

- Store the product in a dry and clean place away from children, preferably in its original packaging.
- Shut down the product before transport.
- Only transport the product in its original packaging. Do not throw away the packaging as it could be used for future transportation. Protect the product during transport (e.g., use Bungee straps) and prevent it from falling, overturning, external impact, and shake, especially when it is transported by vehicles.

⚠ WARNING : This product contains a built-in lithium battery. Lithium batteries are considered as dangerous goods that can only be transported if local laws and regulations allow.



: If you plan to travel with the product by air or other means of transportation, please confirm with your transportation company whether the product is allowed to transport.

6. Disposal



This mark indicates that this product should not be disposed of with other household waste throughout the European Union regions. To prevent possible harms to the environment and health of human beings from unbounded waste disposal, it is our responsibility to recycle it in order to promote the sustainable use of resources. To dispose of used products, please contact recycling organizations or the retailer of the product. They will recycle this product in an environmentally friendly manner.



Dispose of the battery according to environment protection requirements. Do not throw away the battery together with the household waste. Contact the recycling organization in your community or the retailer of this product.



Packaging materials can be transferred back to the raw material cycle. Dispose of packaging materials in accordance with legal requirements. Information can be obtained from your community's recycling organization.

Code	Error	Description	Recommended Actions
1	Overcurrent Protection	The instantaneous output current of the controller exceeds the current limit range	Recovered When the output current of the controller is less than MAX current
2	Low-voltage protection	Battery voltage lower than 30 ± 1 V	1: The fault will be relieved after charging 2: Change the battery
3	Motor phase wire failure	Motor phase line short circuit when unlocking	1:Please check the cable connector, make sure that they connect properly 2:Change the motor extension cable to check If the cable is available 3:Change the display to check the display is available 4:Change the motor to check the motor is available 5:Change the controller to check the motor is available
5	Drive upper bridge failure	Drive High-sideMOSFET tube damaged or breakdown	Change the controller
6	Drive down bridge failure	Drive Low-sideMOSFET tube damaged or breakdown	Change the controller
7	Motor hall signal abnormality	Hall line sequence is wrong or poorly connected	1:Please check the cable connector, make sure that they connect properly 2:Change the motor extension cable to check If the cable is available 3:Change the display to check the display is available 4:Change the motor to check the motor is available 5:Change the controller to check the motor is available
8	Motor Over temperature protection	Motor temperature higher than normal working temperature	1.Stop riding and cool down, wait for the error to be removed by itself 2.Change the motor
9	Lever failure	Handlebar malfunction or poor connection	1.Check the connection of the switch handle and eliminate the poor contact 2.Change the handle
15	Controller firmware missing	Controller program upgrade failed	1: Re-upgrade controller program 2: Change the controller
18	Lever not returned	Throttle not returned or damaged	1.Put the throttle back on line 2.Replace the throttle 3.Release the throttle

Code	Error	Description	Recommended Actions
19	Left brake knob not returned	The left brake does not return or the left brake is damaged when starting up	1. Return the left brake lever 2. Replace the left brake
20	Right brake knob not returned	The right brake does not return or the left brake is damaged when starting up	1. Return the right brake lever 2. Replace the right brake
25	Electronic controller heartbeat error	The controller heartbeat packet cannot receive data	Change the controller
29	Overvoltage	The battery voltage exceeds 60V	1:Change a new battery to check if the battery is available. 2:Change a new controller to check if the controller is available
31	Controller overheating	Controller temperature reaches the protection value	1:If the Error shows when you are riding, the system needs to cool down. Don't worry. 2:If the Error shows when the bike doesn't work too much, update the software of the controller to check the latest software. 3:Change the controller to check the controller is available.