



The manufacturer reserves the right to change and release product firmware updates and to keep this manual up to date.
<https://www.okai.co>

OKAI EB50



Instruction Manual

1.Introduction	02
1-1.Technical Data	03
1-2.Symbol Explanations	05
1-3.List of finished product and parts	06
2.Intended Use	07
3.Safety Instructions	07
3-1.Safety instructions	07
3-2.Battery safety precautions	10
3-3.Safety instructions for battery charger	10
4.How To Use	11
4-1.Instrallation instructions	11
4-2.Charging the battery	18
4-3.Ride preparation	19
5.Maintenance,Cleaning and Service	19
5-1.Maintain	19
5-2.Clean	19
5-3.Storage and transportation	20
6.Handling	20
7.Explanation Of Error Codes	21

Thank you for purchasing the OKAI electric bike.

OKAI sincerely hopes that you can ride the bike safely and enjoy a comfortable riding experience. Since riding a bike carries certain risks, please read this practical manual carefully before riding, and adequately prepare before going on the road. Please keep the instruction manual in case you need it from time to time. If you give the electric bike to others, please also provide them with this user manual. Failure to comply with this user manual may cause serious injury to people or cause damage to the product. OKAI does not assume any responsibility for this. In order to be concise and easy to read, the OKAI E-Bike will be referred to as “product” in the following Content.

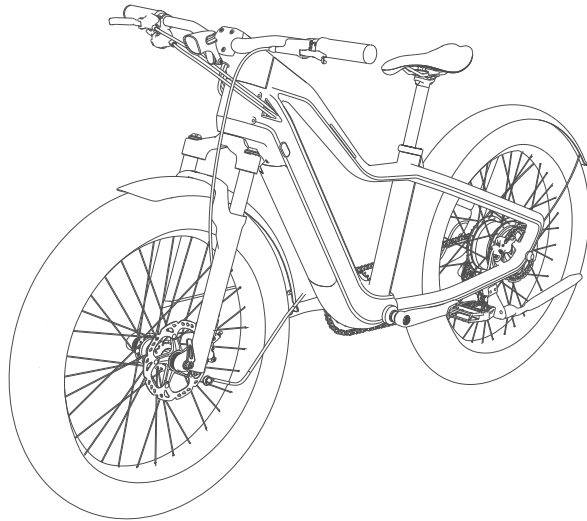

1-1.Technical Data

Item	Content	EB50
Parameter	Dimensions (unfolded): LxWxH	1925*710*1104(mm)
	Frame Size	26"
	N.W.	38kg
	Maximum Speed	32 km/h (20mph)
	Range	≤72km (45miles)
	Adapted Terrain	Flat/Mountain land
	Operating Temperature	0~40°C
	Storage Temperature	-20~45°C
	IP Rating	IPX5
	Charging Time	2.8A<6H
Battery Parameter	Rated Voltage	48V
	Rated Capacity	14.7Ah
	BMS	Negative point port
	Battery Quantity	39Pcs
	Swappable Battery? (Yes or No)	Yes
Motor Parameter	Max Torque	85N.m
	Rated Voltage	48V
	Rated Power	750W
	Max Power	1000W
	Motor Control Mode	Brushless gear reduction motor
Brake	Brake Stopping Distance	≤10m
	Brake Mode	Front:disc brake Rear:disc brake
Tire	Tire Size	Front:26inch Rear:26inch
	Tire Material	Pneumatic tire









Item	Content	EB50
Charger	Input Voltage	100-240V
	Output Voltage	54.6V
	Output Current	2.8A
Rider	Max Load	150kg
	AGE Recommended	>14 years old
	Height Required	140~200cm
Features	Brake Light	Normally on
	Riding Mode	Zero start (rear drive)
	Certification	FCC、CPSC
Packing	Manner Of Packing	1pcs/ctn
	G.W.	45.5kg

*Specifications are subject to change without prior notice.

*Range: When fully charged, with a load of 75kg, an ambient temperature of 25°C, driving on a flat road with human-assisted.

*Factors affecting the range include: speed, ambient temperature, climbing, number of starts and stops, etc.

1-2.Symbol Explanations

DANGER	Indicates a hazard signal with a high degree of danger. If not avoided, death or serious injury may occur.
WARNING	A hazard signal that indicates a moderate hazard. If not avoided, death or serious injury may occur.
CAUTION	A hazard signal that indicates a lower hazard. If not avoided, mild or moderate injury may occur.
	This symbol marks additional information and instructions about the product and its use.
	Please read the instruction manual carefully before use.
	Positive and negative display.
	This product is a second-class protection product.
	Wear personal protective equipment(PPE).
	Please do not use this product after taking alcohol, sedatives or psychotropic drugs.
	Minimum age: 14 years old.
	Do not enter the road with these signs.

1-3.List of finished product and parts

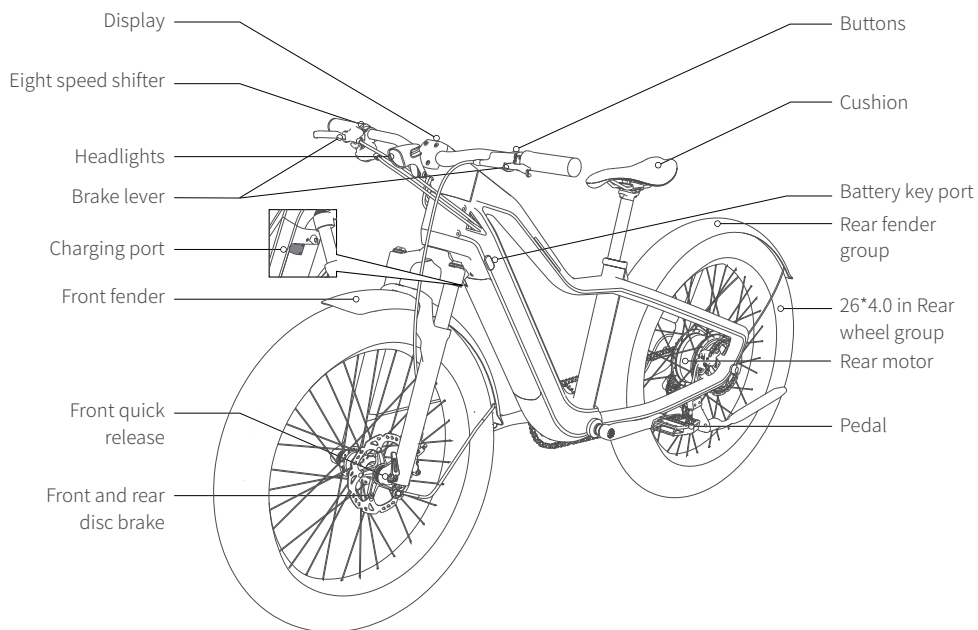

Size: length 1925*width 710*height 1104mm

· An electric bike is intended for sport and entertainment purposes, not for use as a means of transportation, but the transportation function of the product once you drive it into public areas (as permitted by the laws and regulations of your region and country) also carries potential safety risks for all vehicles. Drive strictly in accordance with the instructions in this manual to ensure the safety of yourself and others to the utmost extent, and to ensure compliance with national first-level traffic laws and regulations of various provinces and cities, such as traffic regulations, etc.

· Please note: Once you drive an electric bike on public roads or other public places (as permitted by the laws and regulations of your region and country regarding the use of electric bike on public roads or other public places), even if you fully comply with this safe driving guide operation, you may also face risks caused by illegal driving/improper operation by others, or other vehicles. Just like when walking or riding a bicycle, you may also be injured by other vehicles. As with any vehicle, the faster you drive an electric bike, the longer the distance required to brake, and emergency braking on smooth surfaces may also cause the wheels to slip and lose balance or even fall over. Therefore, it is very important to be vigilant when driving, maintain a proper speed, and maintain a reasonable and safe distance from other people and vehicles. When driving on unfamiliar terrain, stay alert and drive at a low speed.

· Please respect the pedestrian's right of way when driving. Avoid frightening pedestrians, especially children.

· When driving in countries and regions where there are currently no national standards and regulations related to electric bike, such as China, please be sure to comply with the safety requirements for drivers in this manual. Zhejiang Okai Vehicle Co., Ltd will not bear any direct or joint liabilities for any financial losses, losses of life, legal disputes, or any other unfavorable events that occur due to the violation of the recommended uses indicated in this manual.

· To avoid potential injury, do not lend the electric biker to people who can't operate it. If you give the electric bike to a friend to use, please be responsible for your friend's safety, teach them to operate the bike, and tell them to wear protective equipment.

· Please perform a basic inspection of the electric bike before each driving. If you find that there are loose parts, the battery life is obviously reduced, the tires are excessively worn, the steering makes abnormal noises or malfunctions, etc., please stop using the bike immediately, and do not force it to drive.

3.Safety Instructions

This section lists the safety instructions that should be followed when using this product.

3-1.Safety instructions

It may be dangerous to use this product! Learn to use the product step by step and spend enough time in practicing. Please follow all the tips and warnings set forth in this manual to reduce risk of injury. Even if you have enough practice, guidance or expertise, you may still lose control, collide or fall over, which may cause serious harm to yourself or others.

1. Keep the printed instructions for further reference and read carefully before use.
2. Maximum speed allowed: 32 km/h (20mph)
3. Pregnant women, the disabled, and those who suffer from heart, head, back or neck conditions (or have undergone operations on these parts) should not use this product.

4. Do not use this product after taking alcohol, sedatives or psychoactive drugs.
5. Keep a distance of at least 1m/3ft from pedestrians, other vehicles and any obstacles.
6. This product can only be used when the environment permits it and the personal safety of bystanders is guaranteed.
7. Pay attention to the obstacles in front and of those far away.
8. This product may be used by only one person. It is forbidden to use this product with others. Don't make sharp turns when driving the bike at high speeds.
9. Avoid sudden acceleration or sudden braking; do not lean your body for acceleration.
10. Excessive forward or backward is strictly prohibited.
11. Do not misuse this product. Do not use this product on roadsides, ramps, in skate parks, empty swimming pools, or any place similar to sliding plates.
12. Do not use this product to cross obstacles, slopes, ice or snow, nor climb up or down steep slopes, stairs or escalators. Do not expose this product in the rain.
13. Do not use this product in places where the depth of the puddle exceeds 10cm / 3.94in, because water may enter the motor.
14. Don't jump on this product. Don't try to use this product to do any acrobatics or activities not intended.
15. In order to avoid distraction when riding, please do not wear earphones, earplugs, make or answer calls, take pictures or videos or do any activities that are not related to riding so that you may maintain an awareness of your surroundings at all times.
16. Be sure to hold both handles when riding.
17. Avoid using this product at night or in places with poor visibility.
18. When you encounter pedestrians or other obstacles, check if you can pass safely.
19. Please use this product and its accessories at an appropriate temperature. Pay attention to the temperature requirements for battery charging.
20. Please always wear personal protective equipment (to protect wrists, knees, head and elbows) suitable for your weight and size to avoid injury. In working areas, local laws or regulations may have minimum requirements for helmets. In addition, it is suggested that safety mirrors be worn.
21. According to French traffic rules, reflective clothing and helmet is strongly required when riding.
22. Do not hang this product with other products or vehicles.
23. When not used, this product should be parked with the kickstand.
24. Any load added to the handle will affect the stability of the bike.
25. **WARNING!** The braking distance will be extended under humid conditions.
26. **WARNING!** If any mechanical parts are subject to great external pressure and wear, different materials and parts may react differently. If a part exceeds the expected service life, it may suddenly break, which may cause injury. Cracks, scratches and discoloration in the area affected by external pressure indicate that the part has exceeded its service life and should be replaced as soon as possible.
27. Please spend enough time practicing how to use this product, so as to avoid accidents caused by lack of skills.
28. If training is required, the seller may provide corresponding training tutorials
29. When you are approaching pedestrians or cyclists, you may ring the bell to alert them.
30. When passing a protected passage, please dismount from the bike and walk through it.
31. Pay attention to protect your own safety and the safety of others in all cases.
32. Do not use this product for other purposes such as carrying people and objects.
33. Using the brake for long durations may cause it to heat up. Avoid touching them to prevent burns.
34. Regularly check all bolts and screws, especially the axles, folding system, steering system and brake shaft.

35. It is prohibited to refit this product, including steering tubes, steering sleeves, steering rods, folding mechanisms and rear brakes.
36. Accessories and any additional items which are not approved by the manufacturer shall not be used.
37. When riding, the noise should not exceed 70dB.
38. When using the product, users must wear shoes.
39. This appliance can be used by children aged from 14 years and above and persons with reduced physical, sensory or mental capabilities or lack of experience and knowledge if they have been given supervision or instruction concerning use of the appliance in a safe way and understand the hazards involved. Children shall not play with the appliance. Cleaning and user maintenance shall not be made by children without supervision.
40. Traffic in the city has many obstacles to cross such as curbs or steps. It is recommended to avoid obstacle jumps. It is important to anticipate and adapt your trajectory and speed to those of a pedestrian before crossing these obstacles. It is also recommended to get out of the vehicle when these obstacles become dangerous due to their shape, height or slippage.
41. Get closer to your seller so he can refer you to an appropriate training organization.
42. Avoid high traffic areas or overcrowded areas.
43. In any case, anticipate your trajectory and your speed while respecting the code of the road, the code of the sidewalk and the most vulnerable.
44. Notify your presence when approaching a pedestrian or cyclist when you are not seen or heard.
45. Cross the protected passages while walking.
46. In all cases, take care of yourself and others.
47. Power-off the vehicle during charging.
48. Do not divert the use of the vehicle.
49. This vehicle is not intended for acrobatic use.
50. **Caution!** The brake may become hot while in use. Do not touch the brakes after use.
51. Regularly check the tightening of the various bolted elements, in particular the wheel axles, the folding system, the steering system and the brake shaft.
52. Eliminate any sharp edges caused by use.
53. Do not modify or transform the vehicle, including the steering tube and sleeve, stem, folding mechanism and rear brake.
54. The self-tightening nuts as well as the other self-tightening fastenings may lose their efficiency and that they may need to be retightened.
55. **WARNING!** As with any mechanical component, a vehicle is subject to high stresses and wear. The various materials and components may react differently to wear or fatigue. If the expected service life for a component has been exceeded, it may break suddenly, therefore risking causing injuries to the user. Cracks, scratches and discoloration in the areas subject to high stresses indicate that the component has exceeded its service life and should be replaced.
56. In order to prevent theft, it is recommended that physical lock be used when the bike is not in use to secure it.
57. **WARNING!** Risk of Fire and Electric Shock – No User Serviceable Parts.
58. Prolonged exposure to UV rays, rain and the elements may damage the enclosure materials, store indoors when not in use.

Failure to use common sense and heed the above warnings will increase the risk of serious injury or even death, so be careful!

3-2. Battery safety precautions

- The battery should not be exposed to excessive heat such as sunlight, fire or the like. Otherwise there will be a risk of explosion!
- If this product is not used for more than 30 days, please fully charge the battery.
- Fully charge the battery every 90 days. Otherwise, the battery will conduct self-discharge and be damaged.
- If the battery emits a strong smell or becomes hot, stop using the product immediately. Do not open the product casing and don't try to disassemble the battery by yourself.
- Please dispose of the battery correctly and safely.

3-3. Safety instructions for battery charger

- Please use the original battery charger provided with the product for charging.
- The battery charger is not suitable for children under 14 years old, people with mental disorders, those who are disabled, etc., unless they use this product under the supervision or guidance of their guardians.
- Check again whether the power plug and cable are damaged. If so, they must be replaced by the manufacturer, a designated service agent or a person with similar qualifications to avoid danger.
- Before cleaning, storage and transportation, disconnect the battery charger from the power source and allow it to cool down.
- Protect electrical components from moisture. When the battery charger is cleaned or used, do not immerse it in water or other liquids to avoid electric shock. Do not put the battery charger in water. When being charged, this product must be placed in a well-ventilated place. After the battery is fully charged, immediately disconnect the charger from the power source.
- Regularly check whether the battery charger is damaged. A damaged battery charger must be repaired before use. Do not use a battery charger that has been left exposed for a long time or damaged.
- Do not connect a damaged product to the battery charger. There is a risk of electric shock!
- Do not disassemble the battery charger. Repairs must be performed by reliable after-sales service personnel. Incorrect assembly may cause fire or electric shock.
- Do not use the charger near flammable and explosive items, otherwise there is a risk of fire and explosion.
- Please check the technical data before connecting the battery charger to the power source. Improper use may cause fire! The battery charger should be used indoors only.
- Do not misuse the battery charger. The battery charger is only suitable for this product. Use with other products may cause fire or electric shock.
- Make sure that the battery charger and the charging port are properly connected and not blocked by foreign objects.
- Keep the charging port clean, dry, and free from dust and humidity. Do not put any objects on the battery charger, and don't cover it. Otherwise, the battery may overheat.
- Do not place the battery charger near any heat sources.
- Be sure to place the power line in places where no one may trip, step on, or damage it, Otherwise there will be a risk of material damage and personal injury.
- Do not disconnect the battery charger from the power source by pulling the power line. Please manually remove the plug.
- Do not attempt to charge non-rechargeable batteries.

4-1.Instrallation instructions

This section provides information on how to use the product correctly. To ensure user safety and service life, it is important to follow these instructions.



1. Cut the packing straps, remove the white plastic buckle under the package.

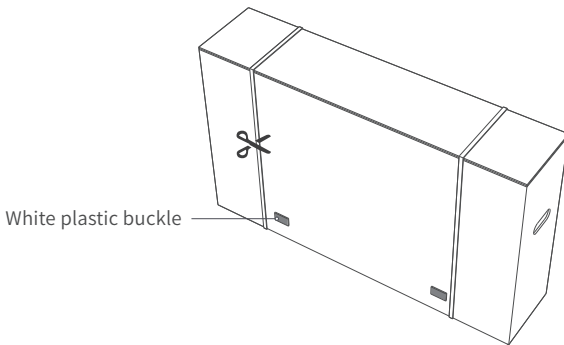

2. Open the box, remove the top three pieces of foam, take out the accessories box.

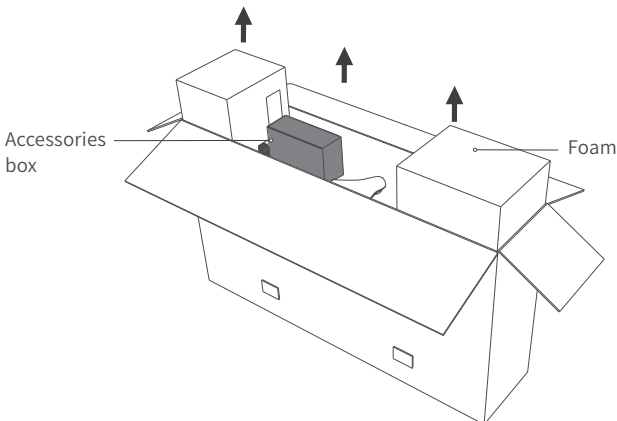

3. Lift the carton and take out the rear wheel fixed foam.

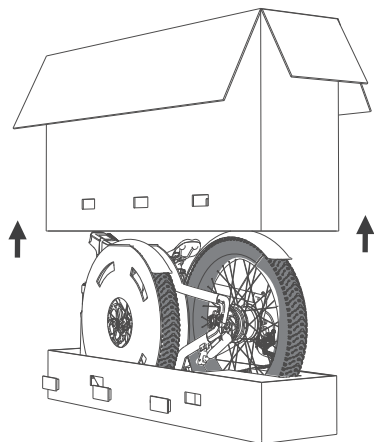

4. Take out the front wheel.

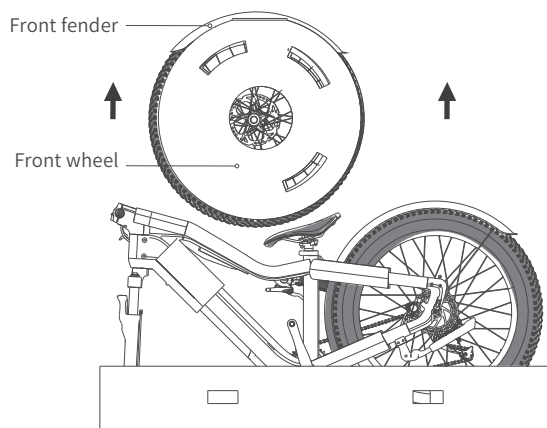

5. Install the handlebar.(Tighten M5 screws with a hex screwdriver,connect wiring terminal.)

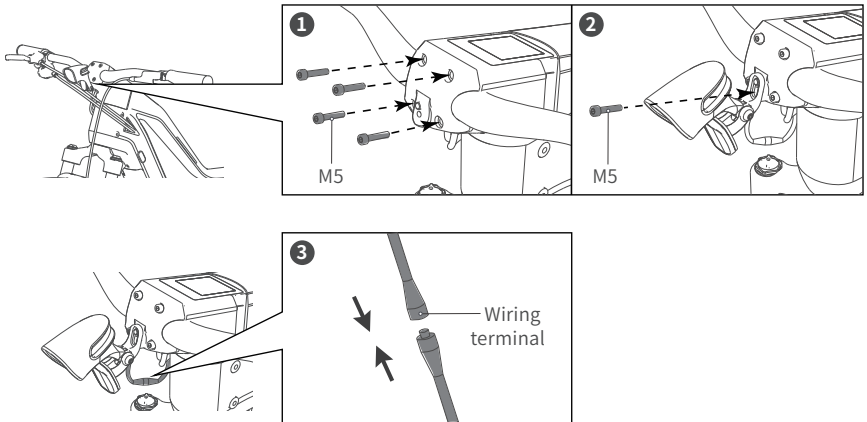

6. Get the vehicle out of package, remove the packaging, put down the kickstand.

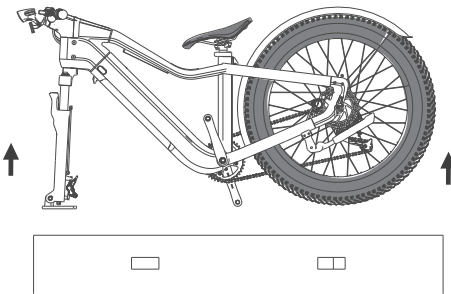

7. Install fenders.(Tighten M6 screws with a hex screwdriver)

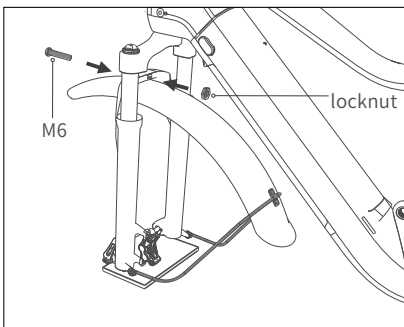

8. Remove the Protection stents and disc brake protection plate respectively.

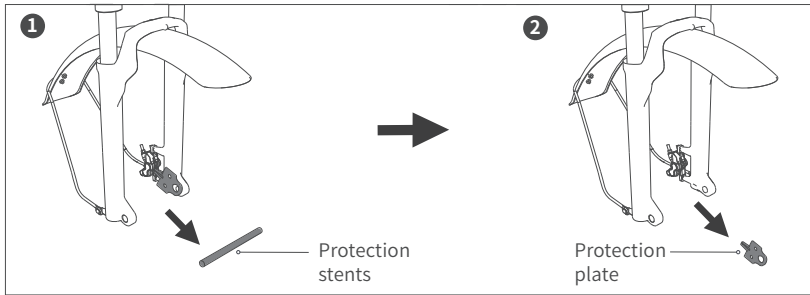

9. Front wheel installation procedures:

a. Align the front wheel hub with the front fork .

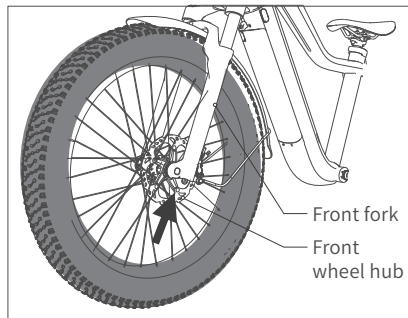

b. Insert the quick release skewer into the front wheel hub, Tighten the quick release skewer.

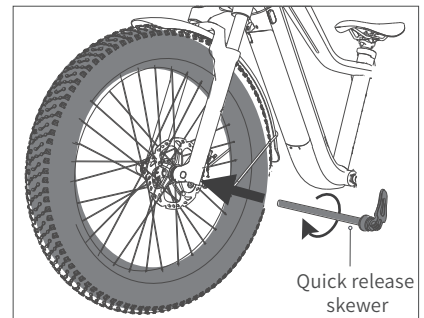

c. Fixed fender support frame
(Tighten M5 screws with a hex screwdriver)

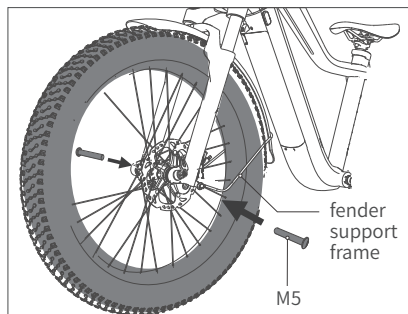

10. Install pedal (Tighten with a no.15 wrench).

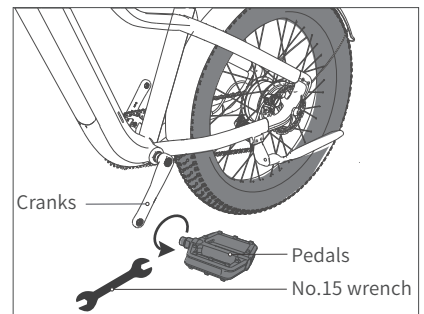

11. Wear a helmet and protective gear.

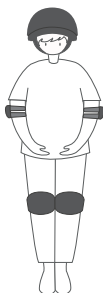

12. Long press the power button, the display screen is lit to indicate that the start up is successful.

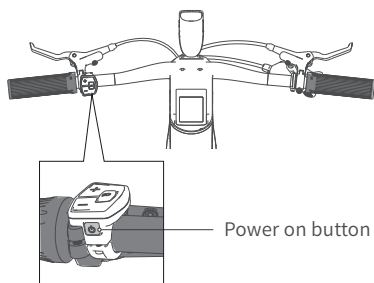

13. Check that the brake levers are working properly.

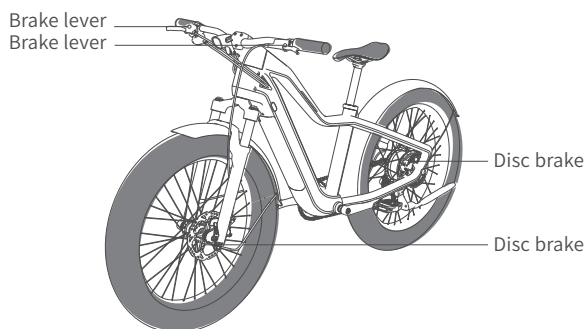

14. Stand with one foot on the pedal and leave with the other and start to slide.

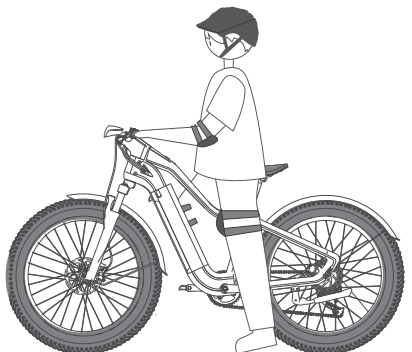

15. Place your other foot on the pedal to keep your feet steady. Focus and keep balance on yourself, step on the pedal for acceleration. For your safety, the motor won't start until the bike reaches 3.1 MPH (5 km/h).

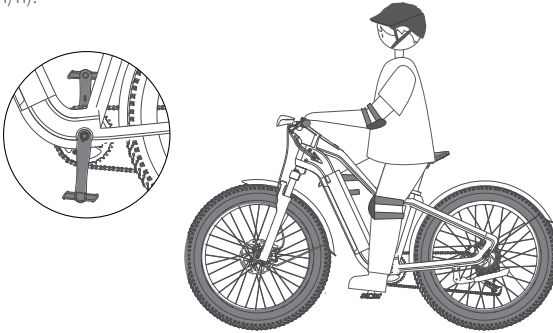

16. Stop pedaling to reduce speed and squeeze brake lever to brake. (Left brake lever controls front wheel braking, right brake lever controls rear wheel braking).

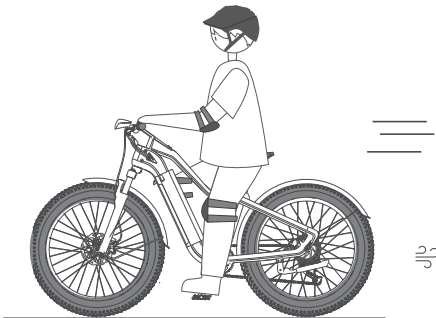

17. To change the center of gravity while turning, turn the handlebar slightly.

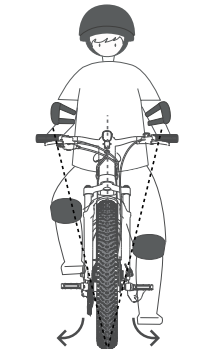

18. Activate the app

Please scan the QR code to download the app (the system version and Bluetooth version are subject to the actual requirements of the app). You can find the cruise control function in the app, and discover more ways to use the bike.



① Install APP, please register/login

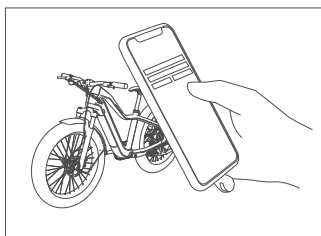

② Open the app, click "Search for Device".
Follow the app prompt to pair with and connect to the bike.

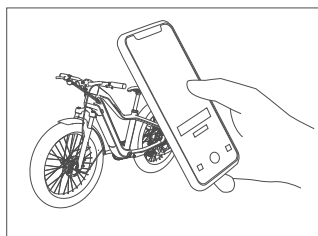

③ Watch the driving guide

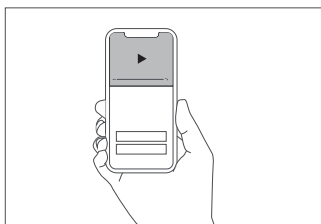

④ Start exploring a new riding experience

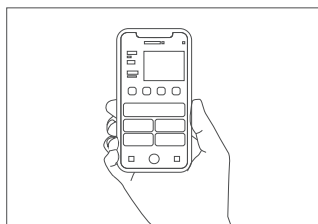

Now, you can use your bike, check the status and detect the ride through the app.

4-2.Charging the battery

·Charger connector

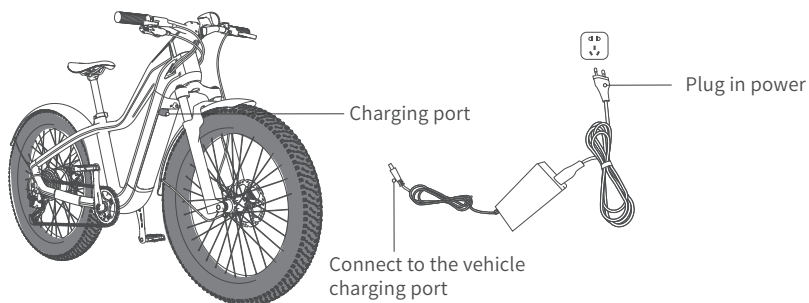

⚠ Note: For first use, please connect the charger to activate vehicle.

·Function button

Power button: Long press the power button to power on/off.

Light button: Press the light button once to turn the headlights on/off while the bike is powered on;

Gear button: Press "+" "-" to adjust 0-3 and pedestrian gears;

0 gear: motor will not output power;

1-3 gear: Motor power increases gradually;

Pedestrian gear: Press "-" in 0 gear to enter the pedestrian gear. Long press "-" to make motor output power ,which is suitable for use on pavement.

·Folding key

Use the NFC icon side of the folding key to touch the display, or press the power button on the handle bar to power on.

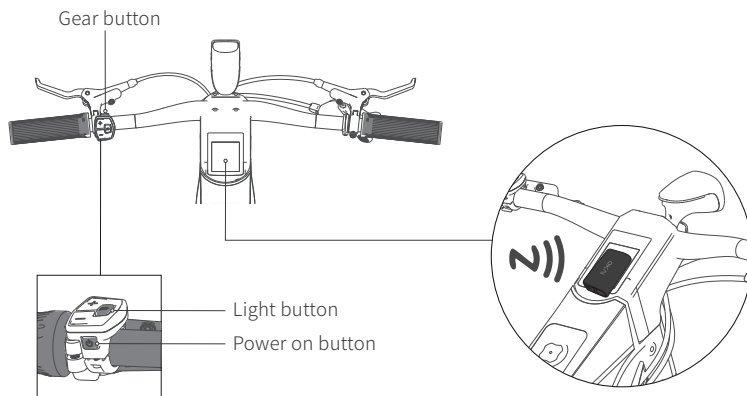

4-3.Ride preparation

Checklist:

- Wheels - check that the wheels are not damaged or excessively worn.
- Loose parts - make sure that all parts, such as nuts, bolts and fasteners are safe. Parts should not make any abnormal sounds.
- Operating area-make sure that the operating area is open and flat without any obstacles.
- Laws and requirements - check and comply with any local laws or regulations. When using this product on public roads, comply with local laws and regulations.
- Safety equipment - always wear personal protective equipment (wrist, knee, head and elbow protection). In some areas, local laws or regulations may require helmets.

⚠ WARNING :Do not ride with the product using one hand. Don't try to perform any stunts or tricks while riding.

⚠ WARNING :Driving at a medium speed will increase mileage. When driving at high speed for a long time, frequently starting, stopping and idling, as well as frequent acceleration and deceleration will reduce mileage.

⚠ WARNING :Do not touch the brake parts with your hands after continuous braking.

5.Maintenance,Cleaning and Service

5-1.Maintain

Please follow the maintenance SOP provided by our company for the maintenance of this product and its accessories. If you have any questions or problems, please contact our company.

5-2.Clean

- Please turn off this product before cleaning.
- Unplug the battery charger from the product before cleaning each time.
- Never use solvents or abrasive cleaners. Never use stiff brushes, metal or sharp objects when cleaning. Otherwise the product's appearance and internal structure will be seriously damaged.
- Clean the battery charger and product with a slightly damp cloth. Afterwards, wipe all parts with a dry cloth.

⚠ WARNING :Do not immerse the product or battery charger in water or other liquids. Do not place the product or battery charger under running water. Doing so creates a risk of electric shock!

⚠ WARNING :This product cannot be cleaned using a power washer.

5-3.Storage and transportation

- Store the product in a dry, clean place, out of the reach of children, preferably in the original packaging.
- During transportation, turn off the product.
- The product can only be shipped in its original packaging. Don't throw away the packaging because shipping the product may be required in the future. Protect the product during transport (for example, using bungee straps) to prevent it from falling or tipping over to protect the product from impact and vibration.

WARNING

:This product contains a built-in lithium battery. Lithium-ion batteries are considered dangerous goods to be transported, and may only be transported when permitted by local laws and regulations.



:If you plan to travel by plane or other means of transportation with your product, please check with your transportation company whether product transportation is feasible.

6.Handling



This mark indicates that this product should not be disposed of with other household waste. In order to prevent possible harm to the environment or human health caused by uncontrolled waste disposal, it is our responsibility to recycle this product to promote the sustainable reuse of material resources. To dispose of the used product, please contact the recycling system or contact the retailer of the product. They can recycle this product environmentally and safely.



Dispose of batteries in accordance with environmental protection requirements. Do not throw away the battery with daily garbage. Contact the recycling system in your community, or contact the retailer where you purchased the product.



Packaging materials can be transported back to the raw material circulation. Dispose of packaging materials in accordance with legal regulations. Relevant information can be obtained from the recycling system in your community.

7.Explanation of error codes

Error number	Error name	The reason	Troubleshooting method
1	Overcurrent Protection	The instantaneous output current of the controller exceeds the current limit range	Recovered When the output current of the controller is less than MAX current.
2	Low-voltage protection	Battery voltage lower than 30 ± 1 V	1:The fault will be relieved after charging. 2:Change the battery.
3	Motor phase wire failure	Motor phase line short circuit when unlocking	1:Please check the cable connector, make sure that they connect properly 2:Change the motor extension cable to check If the cable is available 3:Change the display to check the display is available 4:Change the motor to check the motor is available 5:Change the controller to check the motor is available
7	Motor hall signal abnormality	Hall line sequence is wrong or poorly connected	1:Please check the cable connector, make sure that they connect properly 2:Change the motor extension cable to check If the cable is available 3:Change the display to check the display is available 4:Change the motor to check the motor is available 5:Change the controller to check the motor is available
8	Motor Over temperature protection	Motor temperature higher than normal working temperature	1. Stop riding and cool down, wait for the error to be removed by itself 2.Change the motor
11	Communication failure between instrument and electronic controller	Instrument problem or poorly connector for the communication signal wire	1:Check the controller connection, make sure that they connect properly 2:Check the display connection, make sure that they connect properly 3:Change the display 4:Change the controller
16	BMS firmware missing	Battery program upgrade failed	1: Re-upgrade battery program 2: Change the battery
21	BMS hardware fault information alarm	BMS damaged	Change the battery
22	BMS level 1 fault information alarm	It appears when the battery discharge exceeds 9s~11s with 22A~ 28A current.	Back to normal after staying still for 55s~65s
23	BMS lever 2 fault information alarm	It appears when the battery discharge exceeds 1000ms~4000ms with 35A~ 45A current.	Back to normal after staying still for 55s~65s
24	BMS lever 3 fault information alarm	Appears when the battery discharge exceeds 250ms~350ms with 55A~ 65A current	1:Recovery after charging 2:Recovery after power cut off
27	Battery heartbeat error	The battery heartbeat packet cannot receive data, or the battery user code does not match the central control user code	Change the battery
29	Overvoltage	The battery voltage exceeds 60V	1:Change a new battery to check if the battery is available. 2:Change a new controller to check if the controller is available
30	Torque sensor failure	Loss of torque sensor signal	1:Change the torque sensor 2:Change the controller
31	Controller overheating	Controller temperature reaches the protection value	1:If the Error shows when you are riding, the system needs to cool down. Don't worry. 2:If the Error shows when the bike doesn't work too much, update the software of the controller to check the latest software. 3:Change the controller to check the controller is available.